

V.F. Bolyukh, Yu.A. Kashanskij, A.I. Kocherga, I.S. Schukin

INVESTIGATION OF LINEAR PULSE ELECTROMECHANICAL CONVERTER OF INDUCTION TYPE WITH DOUBLE ARMATURE INTENDED FOR DESTROYING INFORMATION ON SSD STORAGE DEVICE

Purpose. The goal of the paper is to determine the influence of the linear pulse electromechanical converter (LPEC) parameters with a double armature on its electrical, power and temperature indices and experimental verification of the proposed design for an information destruction device in a flat SSD storage device. Methodology. Using the mathematical model that takes into account interrelated electrical, magnetic, thermal and mechanical processes, the influence of geometric parameters on the electrodynamic characteristics and the indices of the induction type LPEC with a double armature spanning the inductor from opposite sides is investigated. Results. It is shown that the currents in the inductor and armature change in accordance with the oscillation-damping law practically in antiphase. The maximum value of the current density in the inductor is 215.8 A/mm^2 , and in each of the identical parts of the double armature it is 299.7 A/mm^2 . The maximum value of electrodynamic forces (EDF) acting in opposite directions on the front and rear of the double armature is 11.99 kN , and the value of the EDF pulse is $4.59 \text{ N}\cdot\text{s}$. Originality. It is established that with axial removal of the rear part of the armature from the inductor, the maximum current densities in the inductor decrease, in the front part of the armature increase, and in the rear part of the armature decrease. The maximum value and the pulse of the EDF between the armature parts decrease. With an increase in the number of turns in the inductor and a decrease in the thickness of the copper bus, all the basic indicators of the LPEC increase. With an increase in the number of turns of the inductor from 26 to 56, the maximum EDF value acting between the parts of the armature increases almost 3 times, and the magnitude of the EDF pulse is 3.3 times. With an increase in the width of the copper bus and the width of the inductor, the main indicators of the LPEC decrease. With an increase in the width of the inductor from 10 mm to 20 mm, the maximum EDF between the armature parts decreases by 1.3 times, and the value of the EDF pulse decreases by 1.2 times. Practical value. Based on the conducted studies, an induction-type LPEC model with a double armature was designed and tested experimentally, designed to destroy information located on a solid-state digital SSD storage device. References 14, figures 9.

Key words: linear pulse electromechanical converter of induction type, double armature, electrodynamic processes, digital SSD storage device, experimental sample.

При помощи математической модели, учитывающей взаимосвязанные электрические, магнитные, тепловые и механические процессы исследовано влияние геометрических параметров на электродинамические характеристики и показатели линейного импульсного электромеханического преобразователя (ЛИЭП) индукционного типа с двойным якорем, охватывающим индуктор с противоположных сторон. При аксиальном удалении задней части якоря от индуктора максимальные плотности токов в индукторе уменьшается, в передней части якоря увеличивается, а в задней части якоря уменьшается. Максимальная величина и импульс электродинамических усилий (ЭДУ) между частями якоря уменьшаются. При увеличении числа витков индуктора и уменьшении толщины медной шины происходит увеличение всех основных показателей ЛИЭП. При увеличении числа витков индуктора от 26 до 56 максимальная величина ЭДУ, действующая между частями якоря, возрастает практически в 3 раза, а величина импульса ЭДУ в 3,3 раза. При увеличении ширины медной шины и ширины индуктора происходит уменьшение основных показателей ЛИЭП. При увеличении ширины индуктора от 10 мм до 20 мм максимальная величина ЭДУ между частями якоря уменьшается в 1,3 раза, а величина импульса ЭДУ уменьшается в 1,2 раза. На основании проведенных исследований был разработан и экспериментально испытан образец ЛИЭП индукционного типа с двойным якорем, предназначенный для уничтожения информации, размещенной на цифровом SSD накопителе. Библи. 14, рис. 9.

Ключевые слова: линейный импульсный электромеханический преобразователь индукционного типа, двойной якорь, электродинамические процессы, цифровой SSD накопитель, экспериментальный образец.

Introduction. Linear pulse electromechanical converters (LPECs) of induction type are widely used to create shock-mechanical pulses [1-4]. Such converters are used in many branches of science and technology as shock-power devices. In construction, electromagnetic hammers and perforators are used; in the mining industry – devices to beat the butt and vibrators; in geological prospecting – vibroseismic sources; in mechanical engineering – hammers with a large range of impact energy and devices for electrodynamic treatment of welded joints; in the chemical and medical-biological industry – vibromixers, metering devices, etc. LPECs are used in test complexes for testing critical equipment for shock loads, in magnetic-pulse devices for pressing

ceramics powders, for cleaning containers from sticking loose materials [4-6]. One of the promising areas is the use of LPECs to destroy information on digital storage devices at unauthorized access [7]. Such LPECs should have a high speed and short working cycle, limited by mass and dimensions, autonomy and develop high shock- mechanical loads. The problem acquires an increased complexity in the destruction of information distributed over the surface of a flat solid state SSD storage device [8].

The most promising for solving this problem is the inductive type LPEC, in which the electrically conductive armature interacts electrodynamicly with the stationary

inductor [4, 9, 10]. When a multiturn inductor is excited from a capacitive energy storage (CES) device, eddy currents are induced in the electrically conducting armature. As a result of this, the electrodynamic forces (EDFs) of repulsion act on the armature, causing its axial movement together with the impact actuator (striker) relative to the inductor.

However, with a rapid change in electromagnetic, mechanical and thermal parameters, the power indices of the induction-type LPEC of traditional design are not high enough [4]. One of the ways to increase these indicators is the development of new LPEC designs. Since in the traditional LPEC design, only one side of the inductor interacts inductively with an armature, a significant part of the magnetic field from the opposite side of the inductor is scattered into the surrounding space, adversely affecting closely located electronic and biological objects, and is not used to create additional EDFs.

Let us consider the design of the LPEC of a coaxial configuration, containing a fixed inductor 1 and a double armature, enclosing the inductor from opposite sides [8] (Fig. 1).

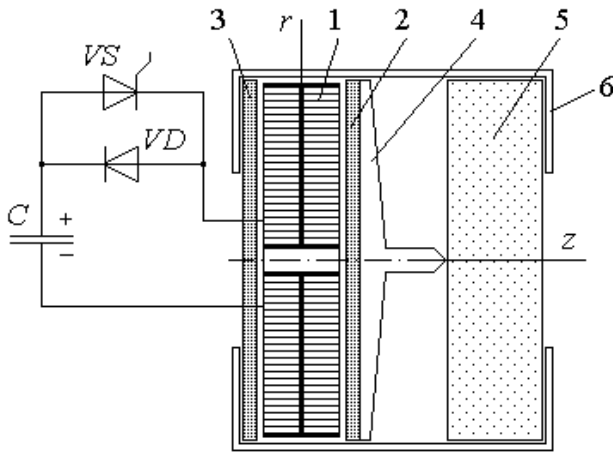

Fig. 1. LPEC with double armature: 1 – inductor; 2 – FPA; 3 – BPA; 4 – striker; 5 – object of action; 6 – fixing clips

The front part of the armature (FPA) 2 and the back part of the armature (BPA) 3 are made in the form of coaxially mounted disks covering the inductor from opposite sides. A striker 4 is connected to the FPA 2, directed towards the object of action 5. The BPA 3 and the object of action 5 on the outer surface are covered by fixing clips 6. Note that the outer electrically conductive screen can play the role of one of the parts of this armature [11].

When a signal is applied to the thyristor VS , the current excites a stationary inductor from the CES C , and due to the emerging magnetic field, eddy currents are induced in each of the parts of the double armature. As a consequence, oppositely directed EDFs of repulsion act on both sides of the double armature on the inductor side, which leads to the total force action of the striker on the object of action. Due to the use of the VD diode, the excitation of the inductor is carried out by a multi-polar

pulse, at which the oscillating-damped character of the current variation is realized.

However, this raises the question of the influence of the parameters of the inductor and the location of the parts of the double armature on the power parameters of the LPEC.

The goal of the paper is determination of ways to increase the power characteristics of a linear pulse electromechanical converter of induction type with a double armature, designed to destroy information in a flat solid state SSD storage device.

Mathematical model. We consider a mathematical model that describes the electromechanical processes of LPEC using the lumped parameters of the active elements – the inductor and the movable parts of the double armature. Electrical processes can be described by a system of equations:

$$i_1 R_1(T_1) + L_1 \frac{di_1}{dt} + \frac{1}{C} \int i_1 dt + \sum_{n=2,3} \left(M_{1n}(z) \frac{di_n}{dt} + i_n e_m \right); \quad (1)$$

$$\frac{1}{C} \int_0^t i_1 dt = U_0; \quad (2)$$

$$i_n R_n(T_n) + L_n \frac{di_n}{dt} + M_{1n}(z) \frac{di_1}{dt} + M_{nm}(z) \frac{di_m}{dt} + i_1 e_3 + i_m e_1 = 0; \quad (3)$$

where $p = 1, 2, 3$ are the indexes of the inductor, FPA and BPA, respectively; $m = 5 - n$; $n = 2, 3$;

$$e_1 = (v_{12}(t) + v_{13}(t)) \frac{dM_{23}}{dz}; \quad e_2 = v_{13}(t) \frac{dM_{13}}{dz}; \quad e_3 = v_{12}(t) \frac{dM_{12}}{dz};$$

$R_p(T_p)$, L_p , i_p , T_p are the resistance, inductance, current and temperature of the p -th active element, respectively; $M_{12}(z)$, $M_{13}(z)$, $M_{23}(z)$ are the mutual inductances between the corresponding p -th active elements; $v_{13}(t)$, $v_{12}(t)$ are the oppositely directed speeds of the BPA and the FPA relative to the inductor along the z axis, respectively.

The solution of equations (1) – (3) for currents in active elements is presented in [12].

Electrodynamic processes can be described by a system of equations:

$$i_1 i_n \frac{dM_{1n}}{dz} = i_n i_m \frac{dM_{nm}}{dz} + (m_n + m_e) \frac{dv_{1n}}{dt} + K_T v_{1n}(t) + 0.125 \pi \gamma_a \beta_a D_{2\max}^2 v_{1n}^2(t) + K_P \Delta z_{1n}(t), \quad (4)$$

where $\Delta z_{13}(t)$, $\Delta z_{12}(t)$ are the oppositely directed movements of the BPA and the FPA relative to the inductor along the z axis; m_2 , m_3 , m_e are the masses of the FPA, the BPA and the striker, respectively; K_T is the coefficient of dynamic friction; γ_a is the density of medium of displacement; β_a is the aerodynamic resistance coefficient; $D_{ex\ m}$ is the maximum armature diameter; K_P is the coefficient of rigidity of the object of action.

The displacements of the BPA and the FPA relative to the inductor can be represented in the form of recurrence relations:

$$\Delta z_{1n}(t_{k+1}) = \Delta z_{1n}(t_k) + v_{1n}(t_k)\Delta t + \frac{\Delta t^2}{2(m_n + m_e)} \times \left[\left(i_1(t_k) \frac{dM_{1n}}{dz} - i_2(t_k) \frac{dM_{nm}}{dz} \right) i_n(t_k) - K_T v_{1n}(t_k) - 0.125 \cdot \pi \cdot \beta_a \gamma_a D_{exn}^2 v_{1n}^2(t_k) - K_p \Delta z_{1n}(t_k) \right] \quad (5)$$

A method for calculating the interrelated electric, magnetic, thermal, and electrodynamic processes with allowance for various nonlinear dependences is described in [12].

As indicators of LPIEC with a double armature we will use:

- the amplitude of the axial EDF f_{z23m} acting on the fixing clips from the oppositely directed forces on the front and back parts of the double armature $f_{z23m} = f_{z2m} - f_{z3m}$, where f_{z2m}, f_{z3m} are the amplitudes of the EDFs acting on the FPA and the BPA, respectively;

- the value of the EDF pulse $F_{z23m} = F_{z2m} - F_{z3m}$ acting on the fixing clips from oppositely directed forces on the front and back parts of the double armature, where F_{z2m}, F_{z3m} are the amplitudes of the EDF pulses acting on the FPA and the BPA, respectively; impulse $F_z = \int f_z(t) dt$;

- maximum values of current densities in the inductor j_{1m} , FPA j_{2m} , and BPA j_{3m} ;

- rise of the temperatures of the inductor $\theta_1 = T_1 - T_0$, FPA $\theta_2 = T_2 - T_0$, and BPA $\theta_3 = T_3 - T_0$, where T_1, T_2, T_3 are the temperature of the inductor, FPA and BPA, respectively; T_0 is the ambient temperature.

The main parameters of the LPEC. Let us consider the LPEC of a coaxial configuration in which both parts of the double armature are identical and are made in the form of a flat disc of technical copper, one of whose sides faces the inductor.

The LPEC has the following initial parameters:

Inductor: outer diameter $D_{ex1}=100$ mm, inner diameter $D_{in1}=10$ mm, height $H_1 = 10$ mm, section of copper bus $a \times b = 1.8 \times 4.8$ mm², the number of turns of the bus $N_1 = 46$ pcs. The inductor is made in the form of a double-layer winding with external electrical terminals.

Parts of the armature: outer diameter $D_{ex2,3}=100$ mm, inner diameter $D_{in2,3}=10$ mm, height $H_{2,3}=3$ mm.

CES: capacitance $C=500$ μ F, voltage $U_0=1$ kV.

The striker has a mass $m_e=0.45$ kg; coefficient of rigidity of the object of action $K_p=3 \cdot 10^7$ N/m. Such stiffness is characteristic for the object of action like the digital SSD storage device when the sharpened striker is acts on it.

Let us consider an excitation circuit that provides a vibrationally damped character of the change in the excitation current of the inductor, at which the highest electrodynamic indices of the LPEC are realized (Fig. 1) [13].

Electrodynamic characteristics and indicators of LPEC with a double armature. Let us consider the influence of geometric parameters on the electromechanical processes of a LPEC of induction type with a double armature. Fig. 2 shows the current densities

in the inductor j_1 and in both parts of the armature $j_2=j_3$, the value of f_{z23} and the impulse F_{z23} of EDF acting between the front and back parts of the double armature for the LPEC with the initial parameters.

In this LPEC, the currents in the inductor and armature change in an oscillatory-damped law almost in antiphase. The maximum value of the current density in the inductor is $j_{1m}=215.8$ A/mm², and in each of the identical parts of the double armature – $j_{2m}=j_{3m}=299.7$ A/mm². EDFs have the form of damped polar pulses, the repetition frequency of which is almost 2 times higher than the oscillation frequency of the inductor current. The maximum value of the EDF acting in opposite directions on the front and back of the double armature is $f_{z3m}=11.99$ kN. And the magnitude of the EDF impulse between the parts of the double armature is $F_{z23}=4.59$ N·s. At the end of the action of the current pulses, the inductor's temperature rise is $\theta_1=0.4$ °C, and the temperature rise of the armature parts is $\theta_2 = \theta_3 = 0.17$ °C.

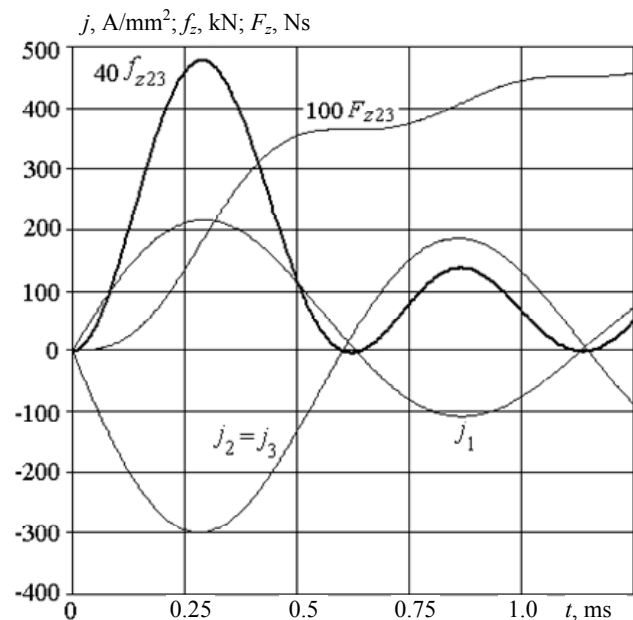

Fig. 2. Electrodynamic indicators of the LPEC with initial parameters

With the axial removal of the BPA from the inductor by a distance $\Delta z_{13}=6$ mm, the following changes are observed (Fig. 3). The current in the FPA by the end of the first half-period is somewhat ahead of the inductor current, while the current in the BPA is almost in antiphase with it. In comparison with the LPEC with the initial parameters, in this case the maximum current density in the inductor j_{1m} decreases by 1.06 times, in the FPA j_{2m} increases by 1.05 times, and in the BPA j_{3m} decreases by 1.92 times. As a result, the maximum EDF value acting on the FPA f_{z2m} increases by 1.07 times, on the BPA f_{z3m} decreases by 4.55 times, which leads to a reduction of the total forces f_{z23m} by 1.55 times.

The EDF impulse F_{z2} acting on the FPA increases by 1.05 times, on the BPA F_{z3} decreases by 4.73 times, which leads to a decrease in the total EDF impulse between the armature parts F_{z23} by 1.58 times.

For a given LPEC, the temperature rise of the inductor θ_1 decreases by 1.33 times, of the FPA θ_2 increases by 1.075 times, and of the BPA θ_3 decreases by 4 times.

Fig. 4 shows the dependence of the electrodynamic parameters of the LPEC with a double armature upon removal of the BPA from the inductor. When removing the BPA from the inductor by a distance of 8 mm, the maximum current density in the inductor decreases by 1.07 times, in the FPA increases by 1.1 times, in the BPA decreases by 2.91 times.

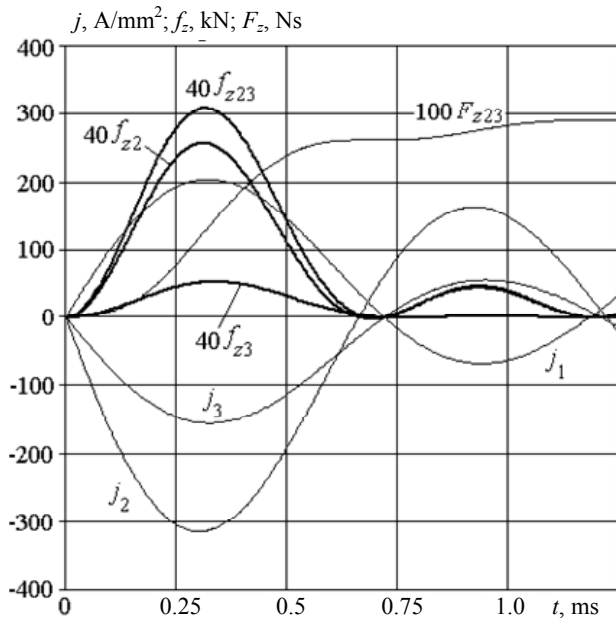

Fig. 3. Electrodynamic indicators of the LPEC, in which the BPA is removed by a distance $\Delta z_{13} = 6$ mm from the inductor

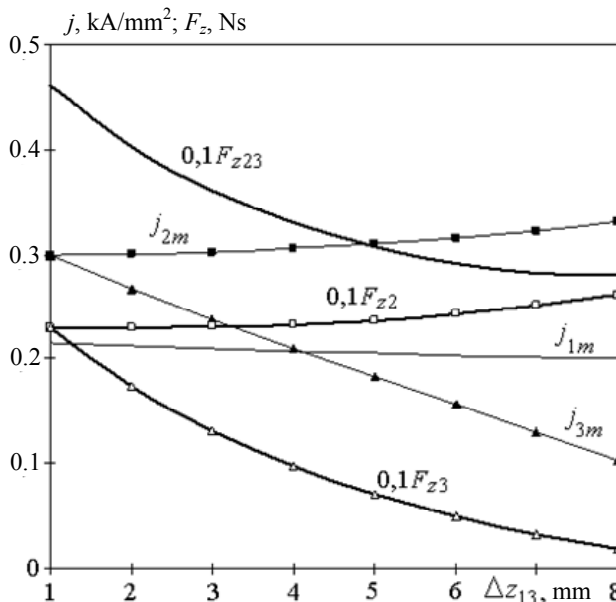

Fig. 4. Dependence of electrodynamic indicators of the LPEC on the removal of the BPA from the inductor by a distance Δz_{13}

The maximum value of the EDF f_{2m} acting on the FPA increases by 1.17 times, on the FHM f_{3m} decreases by 13.12 times, which leads to a reduction of the total forces f_{23m} by 1.62 times. The impulse of the EDF F_{z2} acting on the FPA increases by 1.14 times, on the BPA

F_{z3} it decreases by 12.1 times, which leads to a decrease in the total EDF impulse F_{z23} by 1.64 times.

In this case, the temperature rise of the inductor θ_1 decreases by 1.16 times, of the FPA θ_2 increases by 1.18 times, and on the BPA θ_3 decreases by 6.63 times.

Let us consider the effect of the geometric parameters of the inductor on the indicators of LPEC with a double armature. One such indicator is the thickness of the copper bus b , which affects the number of turns of the inductor N_1 . If the bus has a section $a \times b = 6.8 \times 2.6$ mm², then the inductor has $N_1 = 26$ turns. If the bus has a section $a \times b = 6.8 \times 1.4$ mm², then the inductor has $N_1 = 56$ turns. With an increase in the number of turns of the inductor N_1 , and therefore with a decrease in the thickness of the copper bus b , all the main indicators of the LPEC increase (Fig. 5). With an increase in the number of turns of the inductor from 26 to 56, the maximum current density in the inductor j_{1m} increases by 1.5 times, and in both parts of the armature $j_{2m} = j_{3m}$ in 1.73 times.

This leads to the fact that the maximum EDF value f_{23m} acting between the armature parts increases almost 3 times, and the value of the EDF impulse F_{z23} by 3.3 times. However, in this case, the temperature rise in the inductor θ_1 increases by 2.82 times, and for both parts of the armature $\theta_2 = \theta_3$ by 3.37 times at the end of the working cycle.

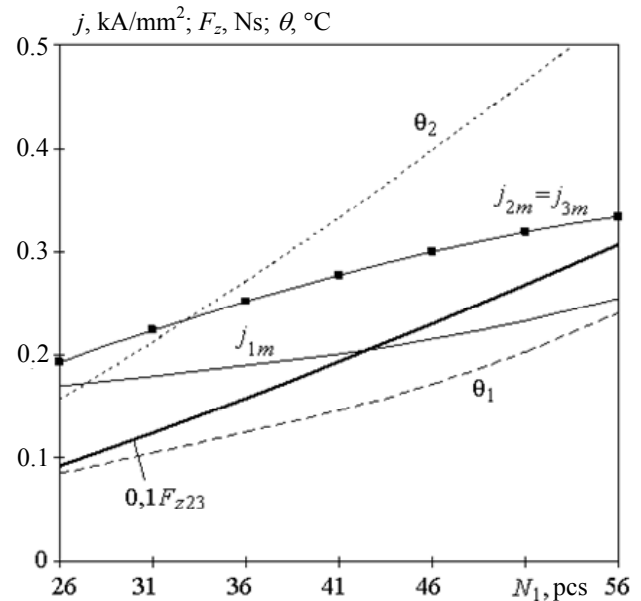

Fig. 5. Dependence of electrodynamic and thermal indicators of the LPEC on the number of turns of the inductor N_1

With an increase in the width of the copper bus, and hence the width of the inductor, the main indicators of the LPEC decrease (Fig. 6). With an increase in the width of the copper bus a from 4.8 mm to 9.8 mm, and hence the width of the inductor H_1 from 10 mm to 20 mm, the following regularities can be noted. The maximum current density in the inductor j_{1m} decreases significantly (more than 2 times), and the maximum current densities in both parts of the armature $j_{2m} = j_{3m}$ decrease insignificantly (by 1.1 times). The maximum value of EDF f_{23m} between the armature parts decreases by 1.3 times, and the value of the EDF impulse F_{z23} decreases by 1.2 times. In this case, the rise of the

temperatures of the inductor θ_1 decreases significantly (almost 4 times), and the temperature rise of the armature $\theta_2 = \theta_3$ decreases insignificantly (by 1.1 times).

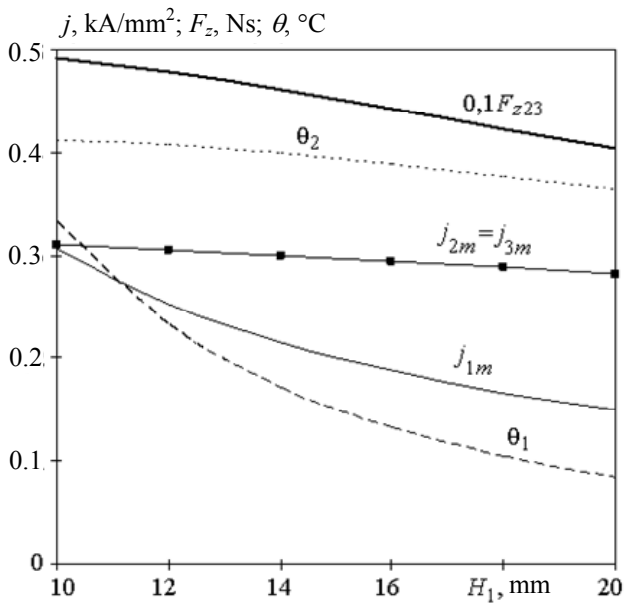

Fig. 6. Dependence of electrodynamic and thermal indicators of the LPEC on the width of the inductor H_1

Design and sample of LPEC for destroying information on the SSD storage device. Based on the conducted research, the design of the LPEC designed to destroy information located on a solid-state digital SSD storage device with surface distributed memory is developed [8].

The device consists of an inductor 1 in the form of two windings 1a and 1b with external electrical terminals 2, between which is located the inductor nonmetallic plate 3 (Fig. 7). The windings of the inductor 1 made in the form of an oval are wound according to the magnetic field from a single ribbon wire and are connected with an inductor plate 3 by means of an epoxy resin.

The device contains an FPA 4 and BPA 5. The inductor 1 is fixed to the object of action – the digital SSD storage device 6 by means of a fixing clip 7 covering their rectilinear sections. The front part of the fixing clip 7a covers the digital storage device 6, and the back part of the clip 7b covers the BPA 5. The parts of the clip are fixed with each other using detachable locks 8.

The impact actuator comprises orderedly arranged sharpened strikers 9 in the form of hardened nails. The hat of each striker is located between the FPA 4 and the impact plate 10, and the striker cores are in the form of a tapered cone and fixed in the holes of the impact plate 10. The FPA 4 and the impact plate 10 are interconnected. FPA 4, BPA 5, inductor plate 3 and shock plate 10 are made in the form of rectangles, which corresponds to the form of a digital SSD storage device 6.

In the angular parts of the inductor plate 3, the guide rails 11 perpendicularly are fixed, which pass through the guide holes of the FPA, the BPA and the impact plate 10.

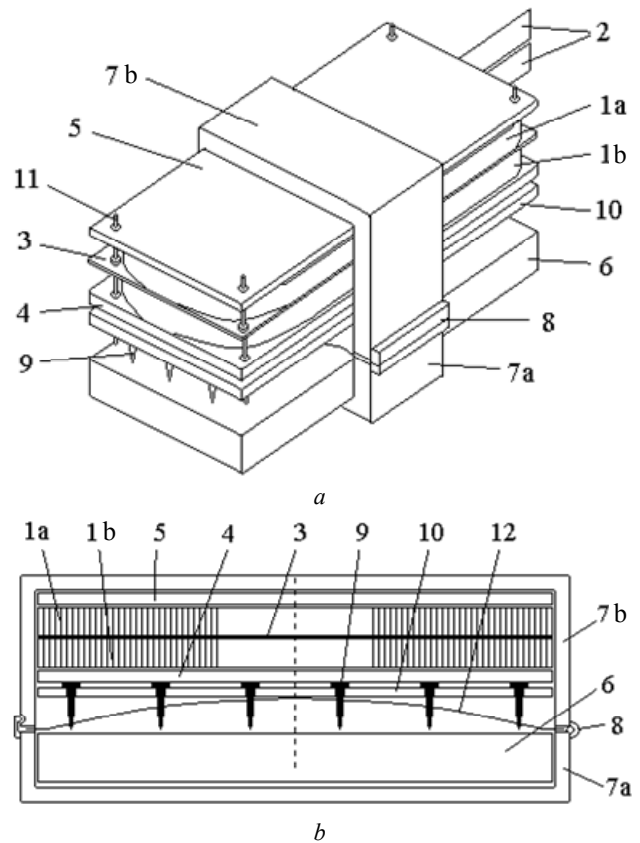

Fig. 7. General view (a) and cross-section (b) of LPEC to destroy information on the SSD storage device

The guide rails are connected to the inductor plate 3. The device comprises a flat spring 12 whose middle part interacts with the shock plate 10 and its ends are fixed relative to the back and front parts of the clip in detachable locks 8. In the initial state of the spring 12, its middle part presses the shock plate 10 together with the FPA 4 to the winding of the inductor 1b, and the winding 1a to the BPA 5.

If it is necessary to destroy information placed on a solid-state digital SSD storage device, for example, when a signal is received about unauthorized access to its information, a capacitive energy storage device is discharged to the inductor. In this case, the shock plate 10 moves with the strikers 9, which penetrate into the digital storage device 6, irrevocably destroying the information on it.

In addition, FPA and BPA screen the magnetic field excited by the inductor, which is favorable for closely located electronic and biological objects [14].

Based on the studies carried out, an experimental LPEC model of an induction type with a double armature was developed.

To conduct experimental studies of the LPEC, a diode-thyristor block, an electronic pulse generating unit with capacitors, a battery and a trigger device were used (Fig. 8,a). In experimental studies, a multilayered structure was used as the object of the impact, made of thin steel sheets backed by sheets of particleboard and fiberglass. Such a design made it possible to visually assess the penetration depth of the strikers into the object of action. As shown by experiments, after the

operation of the LPEC, the striker effectively penetrated almost the entire object of action.

Fig. 9 shows a prototype of LPEC of an induction type with a double armature, designed to destroy information on the SSD storage device and the results of its impact on the multilayer sample.

In the test sample, the inductor was covered with a decorative black film and the fixing clips were improved, which served as the outer casing and fully covered the object of action and the BPA.

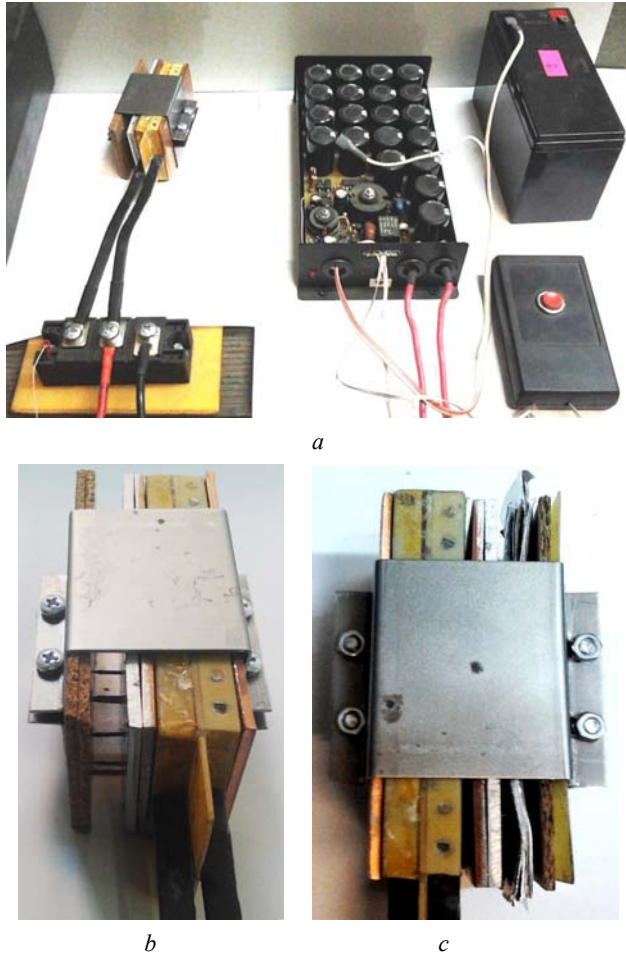

Fig. 8. Equipment for LPEC test (a), experimental LPEC sample in the initial position (b) and after operation (c)

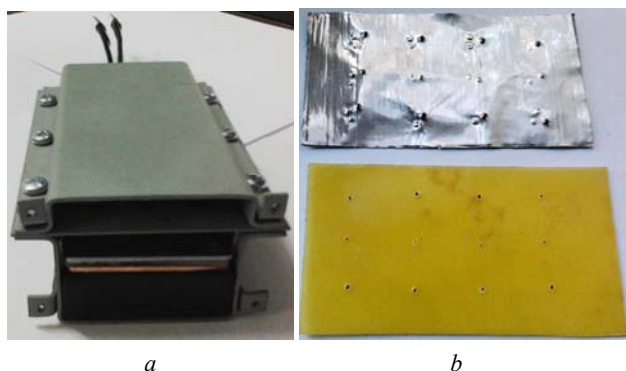

Fig. 9. A LPEC prototype for destroying information on the SSD storage device (a) and the results of its impact on a multilayer sample (b)

Conclusions.

1. Using the mathematical model that takes into account interrelated electrical, magnetic, thermal and mechanical processes, the influence of geometric parameters on the electrodynamic characteristics and indices of the LPEC of the induction type with a double armature covering the inductor from opposite sides was established.

2. The ways of increasing the power indexes of the LPEC are determined – the maximum value and the impulse of the electrodynamic forces between the parts of the double armature. It was established for the first time that the power indexes of the LPEC increase with the maximum approach of both parts of the double armature to the inductor, with an increase in the number of turns and the invariable dimensions of the inductor, with a decrease in the width of the copper bus and the width of the inductor.

3. An induction type LPEC model with a double armature designed to destroy information located on a solid-state digital SSD storage device was developed and experimentally tested.

REFERENCES

1. Tomashevsky D.N., Koshkin A.N. Modeling of linear impulse electric motors. *Russian Electrical Engineering*, 2006, no.1, pp. 24-27. (Rus).
2. Ivashin V.V., Penchev V.P. Features of the dynamics of work and energy diagrams of pulsed electromagnetic drive with parallel and series connection of excitation windings. *Electrical engineering*, 2013, no.6, pp. 42-46. (Rus).
3. Bolyukh V.F., Luchuk V.F., Rassokha M.A., Shchukin I.S. High-efficiency impact electromechanical converter. *Russian electrical engineering*, 2011, vol.82, no.2, pp. 104-110. doi: [10.3103/s1068371211020027](https://doi.org/10.3103/s1068371211020027).
4. Bolyukh V.F., Shchukin I.S. *Lineinye induktsionno-dinamicheskie preobrazovateli* [Linear induction-dynamic converters]. Saarbrücken, Germany, LAP Lambert Academic Publ., 2014. 496 p. (Rus).
5. Ivanov V.V., Pararin S.N., Nozdrin A.A. Semiautomatic installation of magnetic pulse compaction of powders. *Materialovedenie*, 2011, no.7, pp. 42-45. (Rus).
6. Young-woo Jeong, Seok-won Lee, Young-geun Kim, Hyun-wook Lee. High-speed AC circuit breaker and high-speed OCD. *22nd International Conference and Exhibition on Electricity Distribution (CIRED 2013)*, 2013, 10-13 June, Stockholm, Paper 608. doi: [10.1049/cp.2013.0834](https://doi.org/10.1049/cp.2013.0834).
7. Bolyukh V.F., Shchukin I.S. High-performance electromechanical and electromagnetic pulse devices for destruction of information on digital drives. *Electrical engineering and electromechanics*, 2015, no.5, pp. 36-46. (Rus). doi: [10.20998/2074-272x.2015.5.05](https://doi.org/10.20998/2074-272x.2015.5.05).
8. Bolyukh V.F., Luchuk V.F., Shchukin I.S. *Ustroistvo unichtozheniia informatsii, razmeshchennoi na tverdotel'nom tsifrovom SSD nakopitele* [A device for destroying information located on a solid state digital SSD drive]. Patent Russian Federation, no. 2654163, 2018. (Rus).
9. Bissal A., Magnusson J., Engdahl G. Comparison of two ultra-fast actuator concept. *IEEE Transactions on Magnetics*, 2012, vol.48, no.11, pp. 3315-3318. doi: [10.1109/tmag.2012.2198447](https://doi.org/10.1109/tmag.2012.2198447).
10. Schneider Electric Industries SAS. *Electric switching device with ultra-fast actuating mechanism and hybrid switch comprising one such device*. Patent USA, no.8686814, 2014.
11. Bolyukh V.F., Dan'ko V.G., Oleksenko S.V. The Effect of an External Shield on the Efficiency of an Induction-Type

Linear-Pulse Electromechanical Converter. *Russian Electrical Engineering*, 2018, vol.89, no.4, pp. 275-281. doi: **10.3103/s106837121804003x**.

12. Bolyukh V.F., Kocherga A.I., Schukin I.S. Investigation of a linear pulse-induction electromechanical converter with different inductor power supply circuits. *Electrical engineering & electromechanics*, 2018, no.2, pp. 11-17. (Rus). doi: **10.20998/2074-272X.2018.2.02**.

13. Bolyukh V.F., Kocherga A.I., Schukin I.S. Investigation of a linear pulse-induction electromechanical converter with different inductor power supply circuits. *Electrical engineering & electromechanics*, 2018, no.1, pp. 21-28. (Rus). doi: **10.20998/2074-272X.2018.1.03**.

14. Bolyukh V.F., Kocherga A.A., Shchukin I.S. Comparative analysis of constructive types of combined linear pulse electromechanical converters. *Technical electrodynamics*, 2018, no.4, pp. 84-88. (Ukr). doi: **10.15407/techned2018.04.084**.

V.F. Bolyukh¹, Doctor of Technical Science, Professor,
Yu.A. Kashanskij¹, Master of Science,
A.I. Kocherga¹, Postgraduate Student,
I.S. Schukin², Candidate of Technical Science, Associate Professor,

¹National Technical University «Kharkiv Polytechnic Institute»,
2, Kyrpychova Str., Kharkiv, 61002, Ukraine,
phone +380 57 7076427,
e-mail: vfbolyukh@gmail.com

²Firm Tetra, LTD,
2, Kyrpychova Str., Kharkiv, 61002, Ukraine,
phone +380 57 7076427,
e-mail: tech@tetra.kharkiv.com.ua

Received 22.06.2018

How to cite this article:

Bolyukh V.F., Kashanskij Yu.A., Kocherga A.I., Schukin I.S. Investigation of linear pulse electromechanical converter of induction type with double armature intended for destroying information on SSD storage device. *Electrical engineering & electromechanics*, 2018, no.5, pp. 17-23. doi: **10.20998/2074-272X.2018.5.03**.