

S. Bedoui, A. Bayadi

Statistical approach for insulation coordination of high voltage substation exposed to lightning strikes

Introduction. Insulation coordination requires accurate prediction of overvoltages at various points within a substation. Computer simulations of electromagnetic transients in real structures of substations become more precise due to the improvements of used models. **Goal.** This paper discusses in a first step the use of the modified ZnO arrester dynamic model alongside other substation equipment models, considering electrical phenomena like the corona model for reproducing the stresses that lightning can cause in an air-insulated substation and (**method**) then conducting a statistical approach based on the Monte Carlo method. The implemented MATLAB/ATP procedure estimates not only the substation Mean Time between Failures (MTBF), but also is used to select surge arresters or substation basic insulation levels (BILs). In this procedure ATP transients program is used to calculate lightning overvoltages and multicore environment for the calculations. **Results.** The obtained MTBF curves offer guidance for selecting appropriate insulation levels based on specific system requirements and conditions. The obtained results comply well with existing international insulation standards. This valuable approach significantly contributes to the field of lightning protection. References 31, tables 3, figures 10.

Key words: insulation coordination, substation, arrester, lightning overvoltages, basic insulation level, mean time between failures, Monte Carlo method.

Вступ. Координація ізоляції вимагає точного прогнозування перенапруг у різних точках підстанції. Комп'ютерне моделювання електромагнітних перехідних процесів у реальних конструкціях підстанцій стає більш точним за рахунок удосконалення моделей, що використовуються. **Мета.** У цій статті на першому етапі обговорюється використання модифікованої динамічної моделі обмежувача перенапруги ZnO поряд з іншими моделями обладнання підстанції, розглядаються електричні явища, такі як модель коронного розряду, для відтворення напруг, які блискавка може викликати на підстанції з повітряною ізоляцією, та (**метод**) подальшого використання статистичного підходу, що базується на методі Монте-Карло. Впроваджена процедура MATLAB/ATP оцінює не лише середній час напрацювання на відмову підстанції (MTBF), але й використовується для вибору обмежувачів перенапруги або основних рівнів ізоляції підстанції. У цій процедурі використовується програма перехідних процесів ATP для розрахунку грозових перенапруг та багатоядерне середовище для розрахунків. **Результати.** Отримані MTBF криві дають рекомендації щодо вибору відповідних рівнів ізоляції на основі вимог та умов конкретної системи. Отримані результати добре відповідають міжнародним стандартам ізоляції. Цей цінний підхід робить значний внесок у сферу блискавкозахисту. Бібл. 31, табл. 3, рис. 10.

Ключові слова: координація ізоляції, підстанція, обмежувач перенапруги, грозові перенапруги, базовий рівень ізоляції, середній час напрацювання на відмову, метод Монте-Карло.

Introduction. The electrical system parts involved in lightning calculations must be represented taking into account the associated frequency margins [1]. In addition, the procedures must be developed keeping in mind the random nature of lightning phenomena [2]. It is well known that the substation is properly shielded [3, 4]; then, the actual work will only be concerned by lightning hitting the lines that are connected to it [5]. To ensure effective insulation coordination, it is crucial to accurately predict surges at different locations within the substation [6]. This requires consideration the presence of ZnO surge arresters at key points within the substation, which should provide some protective benefits [7, 8]. The analysis of atmospheric overvoltage in electrical substations or transmission lines has always posed a problem in determining the lightning current amplitude which falls on the protected object [9, 10].

This work details the analysis of the insulation coordination of a complete three-phase operational air-insulation substation considering the incoming surges through one of the transmission lines. The overvoltages at the critical points in the substation are measured and compared to the equipments insulation strength. For this purpose 3 scenarios were identified.

In the first one, the substation Mean Time between Failures (MTBF) has been determined knowing the equipment Basic Insulation Level (BIL) and the arrester. In the second one, the adequate BIL has been determined requiring both the MTBF and the arrester. Finally, the suitable arrester has been selected once both BIL and

MTBF are required. In this case, it is necessary to simulate the system for each arrester.

Briefly speaking, this paper discusses the selection of insulation levels, specifically the BIL and the MTBF, which are crucial factors in the reliability of electrical systems, particularly in gas-insulated and air-insulated stations. Gas-insulated stations typically require higher MTBFs, ranging from 300 to 1000 years, while air-insulated stations may still maintain acceptable reliability with MTBFs around 100 years [1].

In such a study, a precise calculation is highly recommended. For that reason, the Monte Carlo statistical analysis technique was chosen [11]. Although it is extremely long due to the extensive number of simulations and the complexity of the system model, it provides exact results [12]. In this paper, this method has been implemented in MATLAB and integrated with the ATP-EMTP program for conducting system simulations. To speed up the overall solution process, MATLAB's parallel calculation feature was employed by using several cores to reduce the computing time in proportion to the number of cores [13, 14]. The dynamic model [15], of which the parameters were optimised using genetic algorithm technique, was used to account for the characteristics of ZnO arresters under lightning overvoltages.

This suggests that the paper provides guidelines for determining appropriate insulation levels based on the type of station and desired level of reliability.

Studied system modelling. The studied system (Fig. 1) is a 400 kV, 50 Hz air-insulated substation in Oued El-Athmania (Algeria) [16]. The substation has 4 input lines, 2 busbars and 2 power autotransformers with 500 MVA. For protection purposes, ZnO surge arresters are installed at a distance of 3 m from the autotransformers. The connected transmission lines are three-phase lines with 2 conductors per phase and an optical fiber ground wire.

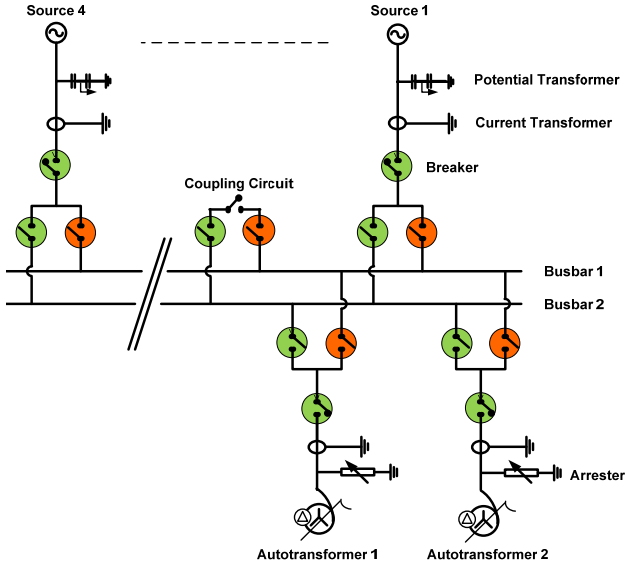

Fig. 1. Single line diagram of the studied substation

The following points summarize the modelling part:

- HV transmission line (Fig. 2,a) is represented by several spans (6 to 7 (390 m each), values within parenthesis are mid-span heights) with a long line termination to avoid reflection [14]. These blocks are represented using frequency-dependent distributed-parameter models. Note that the concatenation of phases and shield wire is also taken into consideration in the modeling of the transmission line.

- towers are represented by the multistory model (Fig. 2,b) proposed in [17-19]. It is composed of 3 sections; each one contains a lossless line with a parallel R-L circuit. The parameters of this model are calculated as:

$$R_i = \frac{-2Z_{ti} \ln \sqrt{\gamma}}{h_1 + h_2} h_i, \quad i = 1, 2; \quad (1)$$

$$R_3 = -2Z_{t3} \ln \sqrt{\gamma}; \quad (2)$$

$$L_i = \frac{\alpha R_i 2H}{V_t}, \quad i = 1, 3, \quad (3)$$

where Z_{ti} is the tower surge impedance; γ is the attenuation coefficient; V_t is the surge propagation velocity; α is the damping coefficient; R is the damping resistance; L is the damping inductance; H is the tower height; h_i is the tower section height.

- Air-gap model (Fig. 2,c) is based on the leader propagation representation [20, 21]. The leader velocity $v(t)$ is calculated as:

$$v(t) = \frac{dL}{dt} = k_1 \frac{U^2}{(D-L)} + k_2 C U^2 v \frac{L}{[D(D-L)]}, \quad (4)$$

where $k_1 = 2 \cdot 10^{-7} \text{ m}^2/\text{V}^2 \cdot \text{s}$; $k_2 = 3 \cdot 10^{-3} \text{ m}^2/\text{V}^2 \cdot \text{A} \cdot \text{s}$; $C = 5 \cdot 10^{-10} \text{ F/m}$; D is the insulator length (5 m); L is the leader length; U is the actual voltage in the gap.

If leader velocity v is obtained at time t , leader length L at $(t + \Delta t)$ is calculated as:

$$L(t + \Delta t) = L(t) + v \cdot \Delta t. \quad (5)$$

The process of calculating the leader length continues until it reaches or exceeds the gap length ($L \geq D$) to sustain the discharge.

- The grounding impedance model of each tower (Fig. 2,d) is approximated by a nonlinear controlled resistance R_t [22, 23] given by:

$$R_t = R_0 / \sqrt{1 + I/I_g}, \quad (6)$$

where R_0 is the grounding resistance (20 Ω); I is the stroke current; I_g is the limiting current to initiate soil ionization, calculated as:

$$I_g = \frac{E_0 \rho}{2\pi R_0^2}, \quad (7)$$

where ρ is the soil resistivity ($\Omega \cdot \text{m}$); E_0 is the soil ionization gradient (400 kV/m).

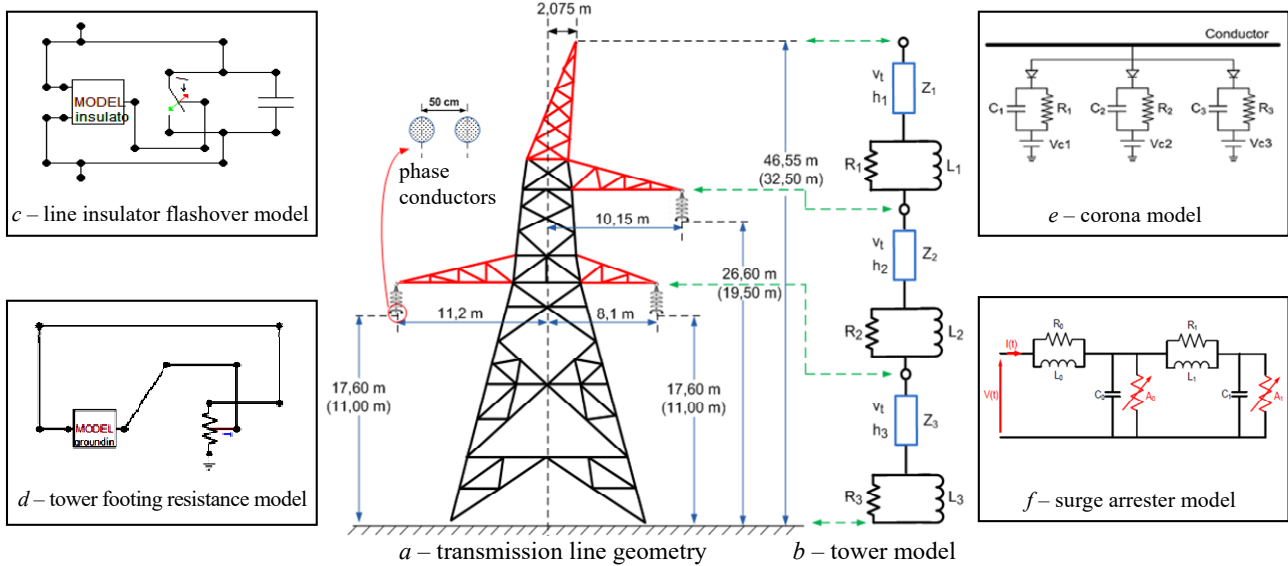

Fig. 2. Modelling of the system elements

• Corona effect (Fig. 2,e) is included into the line model using the circuit proposed in [24] in which:

$$V_{cr} = 23.8r \left(1 + \frac{0.67}{r^{0.4}} \right) \ln \left(\frac{2h}{r} \right); \quad (8)$$

$$C_i = k_c \frac{1}{18 \ln(2h/r)}, \quad (9)$$

where k_c must be adjusted to obtain a propagation model as close as possible to that recommended by standards; r , h are respectively the radius and height of the conductor; V_{cr} is the corona inception voltage; C_i is the corona capacitance.

• A sophisticated model of arrester (Fig. 2,f) based on genetic algorithm optimisation techniques is used [15, 25, 26].

Monte Carlo procedure. The article [14] provides a concise overview of essential steps in the MATLAB/ATP procedure designed for calculating lightning overvoltages in an outdoor substation. This procedure was first implemented in ATP using the models already presented.

Lightning stroke parameters (current magnitude, rise time and tail time) follow a statistical variation assumed to conform to a log-normal distribution, as described in [27-29]. The probability density function then takes the following form:

$$p(x) = \frac{1}{\sqrt{2\pi} \cdot x \cdot \sigma_{\ln x}} \exp \left[-\frac{1}{2} \left(\frac{\ln x - \ln x_m}{\sigma_{\ln x}} \right)^2 \right], \quad (10)$$

where $\sigma_{\ln x}$ is the standard deviation of $\ln x$; x_m is the median value of x .

A correlation coefficient between the generated parameters such as the current magnitude and the rise time is considered [30] (more details in [14]).

The electro-geometric model, which is a set of probabilistic decisions (Fig. 3), is used to determine the lightning impact point on the transmission line [1, 12] (more details in [14]).

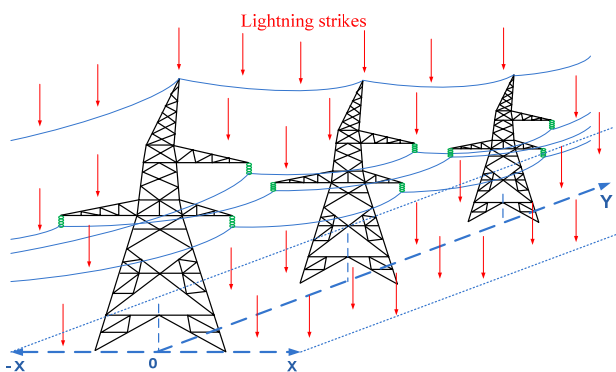

Fig. 3. Area of lightning strikes distribution

MTBF calculation is determined using the faults number (n_f) recorded at the substation equipment (overvoltages number that exceeds the equipments BIL value) and the number of years being simulated (Y_s):

$$MTBF = Y_s / n_f. \quad (11)$$

Once the system model has been implemented in ATP, the main steps of the lightning performance

analysis procedure for the statistical study are summarized in Fig. 4.

Simulation results. In the present work, a statistical approach is proposed to evaluate the lightning performance of the substation. The incoming surges are analyzed to study the substation insulation strength based on the MTBF, BIL and arrester.

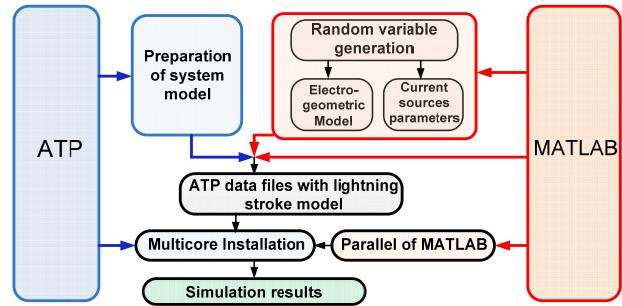

Fig. 4. Lightning performance analysis diagram for the statistical study

With the help of the parallel computing technique, the processing time was significantly reduced from several hours, which was necessary when using a single core, to just a few minutes, with a specific duration depending on the number of cores in use. A set of 60000 random number combinations was generated to evaluate the test system's lightning performance. These combinations equate to an analysis spanning 30769 years, taking into consideration a ground lightning strike density (N_g) of one strike per square kilometer per year.

The work involved analysing incoming surges to a substation through line 1. The surges were filtered using an electro-geometric model, specifically selecting 4690 cases out of a total of 60000 generated cases. This suggests a rigorous process of selection and analysis to focus on relevant surge scenarios, likely aiming to understand the impact of these surges on the substation's operation and/or to optimize its design for lightning protection.

Initially, the overvoltages at critical points in the substation are measured and compared to the equipments insulation strength (BIL). Simulations are repeated for the total number of generated cases, the considered scenarios are presented in Table 1.

Table 1

Studied scenarios			
	MTBF	BIL	Arresters
Scenario A	to be determined	+	+
Scenario B	+	to be determined	+
Scenario C	+	+	to be determined

In the 1st scenario, a standard value of BIL is chosen together with an arrester and the corresponding MTBF will determine.

For the 2nd scenario the desired MTBF is fixed with an arrester, then the corresponding BIL will determine.

The 3rd scenario is proposed to determine a suitable arrester for a desired MTBF and required BIL.

In Table 2, the used ZnO arresters data from ABB are presented corresponding to the 400 kV network system [31].

Main data of ZnO arresters

Arresters	Rated voltage, kV	Maximum service voltage, kV	Temporal overvoltages capacity, kV		Maximum residual voltage, kV _{max}						
					30/60 μs			8/20 μs			
					1 s	10 s	1 kA	2 kA	3 kA	5 kA	10 kA
Arrester 1	330	267	382	363	644	667	684	714	751	823	901
Arrester 2	336	272	389	369	656	679	696	727	765	838	918
Arrester 3	360	291	417	396	702	728	746	779	819	897	983
Arrester 4	372	301	431	409	726	752	771	804	847	927	1021
Arrester 5	378	306	438	415	737	764	783	817	860	942	1037
Arrester 6	390	315	452	429	761	788	808	843	888	972	1070
Arrester 7	420	336	487	462	819	849	870	908	956	1051	1152

Scenario A. As mentioned in Table 1, the 1st scenario aims to determine the substation MTBF knowing the equipments BIL and the arrester. As an example, Fig. 5 presents the simulation results for the case where the arrester №2 is used for two normalized BIL values (1050 and 1175 kV). As observed, for the operating zone recommended by international standards which require a safety margin between 80 and 85 % of BIL, the obtained MTBF for the BIL = 1050 kV ranges between 8 and 53 years. However, for 1175 kV, the MTBF is higher than 263 years. This means that enhancing insulation could be a viable solution.

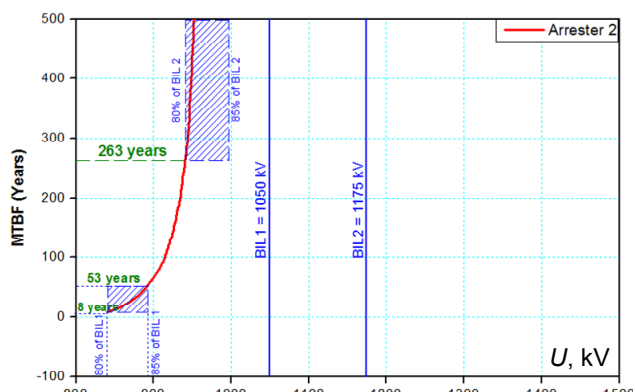

Fig. 5. Selection of the MTBF corresponding to BIL of 1050 kV and 1175 kV (case of arrester 2)

2nd example is chosen for the case where arrester №7 is installed. The BIL value now is taken equal to 1300 kV and the obtained results are shown in Fig. 6. By examining Fig. 6, it is clear that the MTBF ranges between 35 and 264 years, taking into account the safety margins required by international standards.

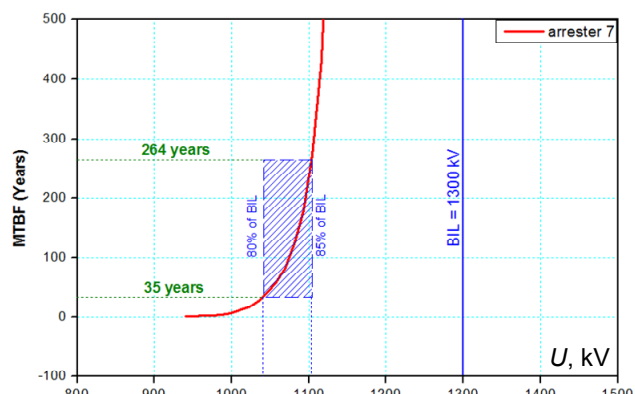

Fig. 6. Selection of the MTBF corresponding to the BIL of 1300 kV (case of arrester 7)

Scenario B. This scenario concerns the case where the desired MTBF is required with a chosen arrester in order to evaluate the adequate BIL value.

In such a situation, the point giving the necessary BIL is the intersection point between the horizontal straight line representing the desired MTBF value and the curve giving the variation of the MTBF as a function of the voltage value. As shown in Fig. 7, where the arrester №5 and the MTBF of 150 years are chosen, the obtained point has a value of 985 kV, which corresponds to 84 % of the BIL 1175 kV, so this BIL was selected for this case. When the operating point is not situated within the safety zone, in this case the highest value of the standard BIL was selected.

As shown in Fig. 8, the obtained operating point which guarantees the use of arrester №3 with an MTBF of 100 years is equal to 928 kV which corresponds to the point situated between 2 safety margin of the BIL 1050 kV and 1175 kV respectively, the largest one is selected in this case for safety reasons. On the other hand, the BIL 1050 kV can be chosen, when the system was protected using the arrester №1.

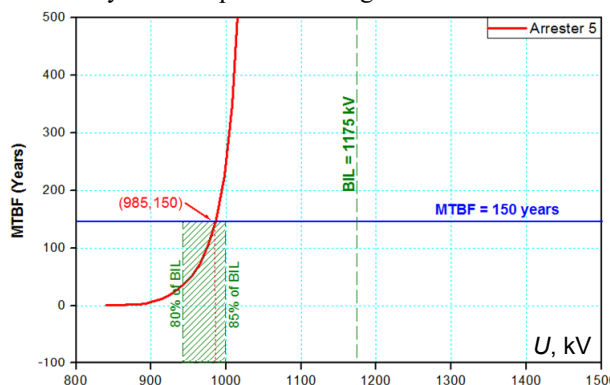

Fig. 7. Selection of the BIL corresponding to a MTBF = 150 years (case of arrester №5)

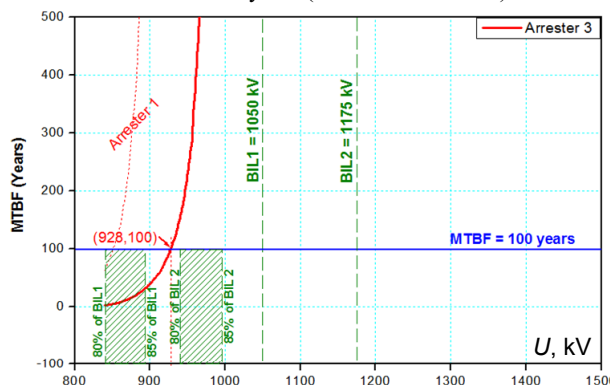

Fig. 8. Selection of the BIL corresponding to a MTBF = 100 years (case of arrester №3)

Scenario C. In this scenario, the aim is to determine the appropriate arrester, when both BIL and MTBF are required. In this case, it is necessary to simulate the system for each arrester. Consequently, a family of curves was obtained giving the variation of the MTBF as a function of the voltage value corresponding to the used arresters. The obtained curves will allow the selection of the appropriate arrester to be used according to the desired BIL and MTBF. In this scenario, only two cases are chosen as shown in Table 3.

Table 3

Studied cases for Scenario C		
Studied case	MTBF, years	BIL, kV
Case 1	100	1050
Case 2	125	1300

The obtained results for the 1st case where the BIL is 1050 kV and the MTBF is 100 years are shown in Fig. 9. As can be seen, arrester №1 has to be selected since it meets the international standards.

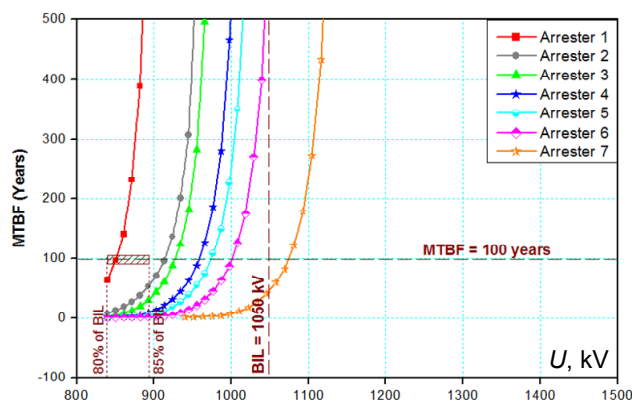

Fig. 9. Selection of the arrester corresponding to a BIL = 1050 kV and MTBF = 100 years

Another example, where the BIL and the MTBF are respectively 1300 kV and 125 years, is presented in Fig. 10. In this case, the arrester №7 has to be selected. The selection of this arrester is closely related to the desired MTBF and BIL.

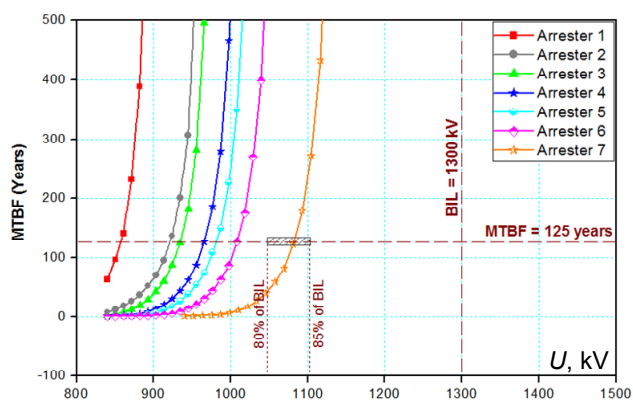

Fig. 10. Selection of the arrester corresponding to a BIL = 1300 kV and MTBF = 125 years

Conclusions. This paper discusses the key aspects of insulation coordination studies. Firstly it focuses on the use of modified ZnO arrester dynamic model alongside other substation equipment models, considering electrical phenomena like the corona model then conducting a statistical study based on the Monte Carlo method.

By incorporating a 20 % safety margin, a series of MTBF curves were generated as a function of voltages, depending on the selected arrester. These curves offer guidance for selecting appropriate insulation levels based on specific system requirements and conditions.

The results obtained can be summarized as follows:

- In the 1st scenario, the substation MTBF was determined (ranging from 8 to 53 years) by selecting BIL = 1050 kV and arrester №2. With BIL = 1175 kV for the same case, the MTBF obtained exceeds 263 years.
- In the 2nd scenario, using arrester №3 with an MTBF of 100 years is illustrated. The operating point, ensuring the intersection between the required values, is 928 kV, leading to select a BIL of 1175 kV for safety reasons.
- In the 3rd scenario, the adequate arrester was arrester №1 for a BIL of 1050 kV and an MTBF of 100 years. However, when a BIL of 1300 kV and an MTBF of 125 years were selected, arrester №7 was found the most appropriate choice.

These results demonstrate good alignment with international insulation standards. It is also important to mention that the implemented MATLAB/ATP procedure uses a statistical approach based on the Monte Carlo method in which ATP is used to estimate lightning overvoltages and the calculations are carried out with a multicore installation.

Moreover, the adopted methodology, focusing on air-insulated substations, can be extended to other substation technologies, such as GIS substations, by adjusting the specified models. This valuable approach significantly contributes to the field of lightning protection.

Conflict of interest. The authors declare that they have no conflicts of interest.

REFERENCES

1. Hileman A.R. *Insulation Coordination for Power Systems*. CRC Press, 2018, 767 p. doi: <https://doi.org/10.1201/9781420052015>.
2. Alto P. *Transmission Line Reference Book – 345 kV and Above. 2nd Edition*. Electric Power Research Institute, California, 1982. 625 p.
3. *BS EN 60071-2. Insulation Coordination Part 2. Application Guide*. 1997. 378 p.
4. *IEEE Std 1313.2-1999. IEEE Guide for the Application of Insulation Coordination*. 1999. 68 p. doi: <https://doi.org/10.1109/IEEESTD.1999.90576>.
5. Savic M.S., Savic A.M. Substation Lightning Performance Estimation Due to Strikes Into Connected Overhead Lines. *IEEE Transactions on Power Delivery*, 2015, vol. 30, no. 4, pp. 1752-1760. doi: <https://doi.org/10.1109/TPWRD.2015.2404771>.
6. *IEC TR 60071-4. Insulation co-ordination – Part 4: Computational guide to insulation co-ordination and modelling of electrical networks*. 2004. 118 p.
7. *IEC 60099-4:2014. Surge arresters – Part 4: Metal-oxide surge arresters without gaps for a.c. systems*, 2014, 353 p.
8. Bedoui S., Bayadi A., Haddad A.M. Analysis of lightning protection with transmission line arrester using ATP/EMTP: Case of an HV 220 kV double circuit line. *45th International Universities Power Engineering Conference UPEC2010*, Cardiff, UK, 2010, pp. 1-6.
9. Takami J., Okabe S., Zaima E. Study of Lightning Surge Overvoltages at Substations Due to Direct Lightning Strokes to Phase Conductors. *IEEE Transactions on Power Delivery*, 2010, vol. 25, no. 1, pp. 425-433. doi: <https://doi.org/10.1109/TPWRD.2009.2033975>.

10. Nowak W., Tarko R. Computer Modelling and Analysis of Lightning Surges in HV Substations due to Shielding Failure. *IEEE Transactions on Power Delivery*, 2010, vol. 25, no. 2, pp. 1138-1145. doi: <https://doi.org/10.1109/TPWRD.2009.2033077>.
11. Zio E. *The Monte Carlo Simulation Method for System Reliability and Risk Analysis*. Springer Publ., 2013. 198 p. doi: <https://doi.org/10.1007/978-1-4471-4588-2>.
12. Martínez J.A., Castro-Aranda F. Lightning Performance Analysis of Overhead Transmission Lines Using the EMTP. *IEEE Transactions on Power Delivery*, 2005, vol. 20, no. 3, pp. 2200-2210. doi: <https://doi.org/10.1109/TPWRD.2005.848454>.
13. Martínez-Velasco J.A., Corea-Araujo J.A., Bedoui S. Lightning Performance Analysis of Transmission Lines Using Parallel Computing. *European EMTP-ATP Conference - EEUG Meeting 2016*, Birmingham, England, 2016.
14. Bedoui S., Bayadi A. Probabilistic evaluation of the substation performance under incoming lightning surges. *Electric Power Systems Research*, 2018, vol. 162, pp. 125-133. doi: <https://doi.org/10.1016/j.eprsr.2018.05.011>.
15. Bayadi A. Parameter identification of ZnO surge arrester models based on genetic algorithms. *Electric Power Systems Research*, 2008, vol. 78, no. 7, pp. 1204-1209. doi: <https://doi.org/10.1016/j.eprsr.2007.10.001>.
16. Sonelgaz Engineering Subcommittee. *Specifications for the Construction of HV Electrical Substations*. 2004.
17. Dommel H.W. *Electromagnetic Transients Program Theory Book*. BPA, Portland, USA, 1986. 631p.
18. Ishii M., Kawamura T., Kouno T., Ohsaki E., Shiokawa K., Murotani K., Higuchi T. Multistory transmission tower model for lightning surge analysis. *IEEE Transactions on Power Delivery*, 1991, vol. 6, no. 3, pp. 1327-1335. doi: <https://doi.org/10.1109/61.85882>.
19. Baha Y., Ishii M. Numerical electromagnetic field analysis on lightning surge response of tower with shield wire. *IEEE Transactions on Power Delivery*, 2000, vol. 15, no. 3, pp. 1010-1015. doi: <https://doi.org/10.1109/61.871367>.
20. Shindo T., Suzuki T. A New Calculation Method of Breakdown Voltage-Time Characteristics of Long Air Gaps. *IEEE Transactions on Power Apparatus and Systems*, 1985, vol. PAS-104, no. 6, pp. 1556-1563. doi: <https://doi.org/10.1109/TPAS.1985.319172>.
21. Harada T. V-t Characteristics of Air Gaps for Steep Front Impulse Voltage. *Proceedings of 3rd ISH Milan*, 1979, vol. 52, no. 6, pp. 372-376.
22. CIGRE WG 33-01. *Guide to Procedures for Estimating the Lightning Performance of Transmission Lines*. CIGRE Brochure 63, 1991.
23. Boumous S., Boumous Z., Anane Z., Nouri H. Comparative study of 220 kV overhead transmission lines models subjected to lightning strike simulation by using electromagnetic and alternative transients program. *Electrical Engineering & Electromechanics*, 2022, no. 4, pp. 68-74. doi: <https://doi.org/10.20998/2074-272X.2022.4.10>.
24. Gallagher T.J., Dudurych I.M. Model of corona for an EMTP study of surge propagation along HV transmission lines. *IEE Proceedings - Generation, Transmission and Distribution*, 2004, vol. 151, no. 1, pp. 61-66. doi: <https://doi.org/10.1049/ip-gtd:20030927>.
25. Modeling guidelines for fast front transients. *IEEE Transactions on Power Delivery*, 1996, vol. 11, no. 1, pp. 493-506. doi: <https://doi.org/10.1109/61.484134>.
26. Modeling of metal oxide surge arresters. *IEEE Transactions on Power Delivery*, 1992, vol. 7, no. 1, pp. 302-309. doi: <https://doi.org/10.1109/61.108922>.
27. Martínez Velasco J.A., Corea Araujo J., Bedoui S. Lightning performance analysis of transmission lines using the Monte Carlo method and parallel computing. *Ingeniare. Revista Chilena de Ingeniería*, 2018, vol. 26, no. 3, pp. 398-409. doi: <https://doi.org/10.4067/S0718-33052018000300398>.
28. Chowdhuri P., Anderson J.G., Chisholm W.A., Field T.E., Ishii M., Martínez J.A., Marz M.B., McDaniel J., McDermott T.E., Mousa A.M., Narita T., Nichols D.K., Short T.A. Parameters of lightning strokes: a review. *IEEE Transactions on Power Delivery*, 2005, vol. 20, no. 1, pp. 346-358. doi: <https://doi.org/10.1109/TPWRD.2004.835039>.
29. Kniaziev V.V. Determination of the probability of a lightning strike in the elements of the object taking into account the statistical distribution of the current value. *Electrical Engineering & Electromechanics*, 2023, no. 5, pp. 57-62. doi: <https://doi.org/10.20998/2074-272X.2023.5.08>.
30. Borghetti A., Nucci C.A., Paolone M. An Improved Procedure for the Assessment of Overhead Line Indirect Lightning Performance and Its Comparison with the IEEE Std. 1410 Method. *IEEE Transactions on Power Delivery*, 2007, vol. 22, no. 1, pp. 684-692. doi: <https://doi.org/10.1109/TPWRD.2006.881463>.
31. ABB High Voltage Products. *Surge Arresters – Buyer's Guide*. Edition 6, 2008, Catalog Publ. 1HSM 9543.

Received 28.02.2024

Accepted 26.04.2024

Published 20.06.2024

S. Bedoui¹, Doctor of Science,

A. Bayadi², Professor,

¹ Laboratory of Electrical Engineering and Automatic (LGEA),

University of Oum El Bouaghi, Algeria,

e-mail: bs_1182@yahoo.fr (Corresponding Author)

² Automatic Laboratory of Setif (LAS),

University of Setif-1, Algeria,

e-mail: a_bayadi@univ-setif.dz

How to cite this article:

Bedoui S., Bayadi A. Statistical approach for insulation coordination of high voltage substation exposed to lightning strikes. *Electrical Engineering & Electromechanics*, 2024, no. 4, pp. 55-60. doi: <https://doi.org/10.20998/2074-272X.2024.4.07>