

## Transmission line planning using global best artificial bee colony method

**Introduction.** Network expansion, substation planning, generating expansion planning, and load forecasting are all aspects of modern power system planning. The **aim** of this work is to solve network planning considering both future demand and all equality and inequality constraints. The transmission network design problem for the 6-bus system is considered and addressed using the Global Best Artificial Bee Colony (GABC) method in this research. The program is written in the Matrix Laboratory in MATLAB environment using the proposed methodology. **Novelty** of the work consist in considering the behavior of bees to find food source in most optimized way in nature with feature of user based accuracy selection and speed of execution selection on any scale of the system to solve Transmission Lines Expansion Problem (TLEP). The proposed method is implemented on nonlinear mathematical function and TLEP function. When demand grows, the program output optimally distributes new links between new generation buses and old buses, determines the overall minimum cost of those links, and determines if those linkages should meet power system limits. **Originality** of the proposed method is that it eliminated the need of load shedding while planning the future demand with GABC method. **Results** are validated using load flow analysis in electrical transient analyzer program, demonstrating that artificial intelligence approaches are accurate and particularly effective in non-linear transmission network planning challenges. **Practical value** of the program is that it can use to execute cost oriented complex transmission planning decision. References 15, table 4, figures 3.

**Key words:** artificial intelligence, artificial bee colony, transmission line network planning, load flow analysis.

**Вступ.** Розширення мережі, планування підстанцій, планування розширення виробництва та прогнозування навантаження - все це аспекти планування сучасної енергосистеми. **Мета** цієї роботи полягає в тому, щоб вирішити мережеве планування з урахуванням як майбутнього попиту, так і всіх обмежень рівності та нерівності. У цьому дослідженні проблема проектування мережі передачі для системи з шістьма шинами розглядається і вирішується з використанням методу Global Best Artificial Bee Colony (GABC). Програма написана у Matrix Laboratory у середовищі MATLAB за запропонованою методикою. **Новизна** роботи полягає у розгляді поведінки бджіл для пошуку джерела їжі найбільш оптимальним способом у природі з можливістю вибору користувачем точності та вибору швидкості виконання у будь-якому масштабі системи для вирішення проблеми розширення ліній електропередачі (TLEP). Пропонований метод реалізований на нелінійній математичній функції та функції TLEP. Коли попит зростає, вихідні дані програми оптимально розподіляють нові з'єднання між шинами нового покоління та старими шинами, визначають загальну мінімальну вартість цих з'єднань та визначають, чи ці з'єднання повинні відповідати обмеженням енергосистеми. **Оригінальність** запропонованого методу полягає в тому, що він усуває необхідність скидання навантаження під час планування майбутнього попиту методом GABC. **Результати** підтверджуються за допомогою аналізу потоку навантаження у програмі аналізу перехідних процесів, демонструючи, що підходи штучного інтелекту точні та особливо ефективні під час вирішення завдань планування нелінійної мережі передачі. **Практична цінність** програми полягає в тому, що вона може бути використана для виконання економічно орієнтованого комплексного рішення щодо планування передачі. Бібл. 15, табл. 4, рис. 3.

**Ключові слова:** штучний інтелект, штучна бджолина родина, планування мережі ЛЕП, аналіз потоку навантаження.

**Introduction.** Electrical power system is a very ancient system that has transitioned from serving a small local load with a local generator to serving a big system load with a massive power system grid over many years. It is now one of the most powerful real-time operating systems. The artificial intelligence algorithm is extremely beneficial for power system expansion and protection. Power system expansion includes planning from 1 to 10 years from now [1].

Static planning entails making decisions from the current year to the next 5 years. One way is to analyze the system for each year separately, regardless of subsequent years. The study described above is known as static planning [2].

The Artificial Bee Colony (ABC) approach is based on actual bees obtaining nectar in the field and sharing information about the food sources with bees in the hive [3]. Power management optimization problem has been solved in [4], which support the use of metaheuristic approach for multi constrained cost optimization problem. The whale optimization is used in [5] to solve dynamic economic emission dispatch problem for the efficient operation of generators in a power network. The cost involved in establishment of new transmission line links is high due to rising real estate price and right of way issues [6]. The problem of rising real estate price and right of way issues necessitates the solution to deal the planning in cost optimized way with maintaining technical standard of the grid.

Load uncertainty is major concern of existing transformation of bidirectional power grid due to unknown photovoltaic generation behind meter by distribution company [7]. Generally Monte-Carlo method is conventionally used for such load uncertainty based

Transmission Lines Expansion Problem (TLEP). However, Monte-Carlo method required considerable amount of time to solve the problem. The location of the bus where the capacity shortage is happened is found using linear programming method [8]. Once the bus has been selected than next step is to estimate how many number of links to be required between old bus to new bus and what should be its cost of planning. The later problem is considered in this work using heuristic approach. ABC method has one of the limitations that it is poor at poor at exploitation [9, 10]. In order to improve the exploitation the proposed method used Global Best Artificial Bee Colony (GABC), which focus more on global best solution. Active power and reactive power mismatch result in to a power system stability problem [11, 12]. So, the TLEP problem is solve in this research by considering all equality and inequality constraint.

**The goal of this paper** is as follows:

- fast programming computation oriented Global Best Artificial Bee Colony based Transmission Lines Expansion Problem algorithm using MATLAB;
- efficient method for validation result of algorithm using Electrical Transient Analyzer Program to insure inaccuracy of software and filter it by manual intervention if needed;
- minimization of Transmission Lines Expansion Problem cost considering equality and inequality constraint.

The paper starts with introduction, where problem statement and need of solution is described with recent literature survey. The next section is focused on behavioral studies and mathematical formulation of

problem. GABC based proposed algorithm is explained in the middle of the paper. In the end of the paper results of MATLAB program and Electrical Transient Analyzer Program (ETAP) analysis is described. Finally, conclusion section ends the paper.

### Global Best Artificial Bee Colony Method.

#### A. Classification of bees:

1) *The employed bee*: It works in the field and stays close to the food source, gathering and memorizing information about the local food supply.

2) *The bystander bee*: It attempts to obtain information about food sources from employed bees who come or stay in the hive to gather nectar. As a result, they are seeking for work.

3) *The scout bee*: As the name implies, they are in charge of finding new sources of nectar nourishment.

**B. Behavior of the bees.** The GABC model's main components include employed bees, spectator bees (or unemployed bees), food sources, and dance places. Working bees are dancing and selecting food sources in a multidimensional search area based on their previous experience. When the search is completed, the information exchange procedure will begin with the bystander bee that are staying and waiting in a hive. The waggle dance may be used to share information. By performing the art of dance to observer bees, employed bees may exchange information such as path, distance to patches of flowers, and superiority of food sources [13]. A waggle dance performance in the hive provides information about the angle between the sun's location and the track of food sources. The initial time interval of the waggle dance represents the distance. The length of time they do the same waggle dance up to reflects the distance of the food sources from their current position. If the waggle dance interval is 1 s, the bee must travel 1 km to reach the food source from the hive. Importantly, alkenes secreted from the stomachs of employed bees communicate the quality of the food supply [14].

The shake dancers are dancing in response to the sun's shifting path. As a result, bees that perform the waggle dance are left at food sources without mistake. The likelihood may be calculated analytically using (1), the information provided by the working bee:

$$p = \left( \frac{0.9 \cdot f_p}{\max(f) + 0.1} \right), \quad (1)$$

where  $p$  is the probability of food;  $f_p$  is the fitness value of the answer number  $p$ , which is directly relative to the nectar amount of the food source in the position number  $p$ .

Using (1), the unemployed bee now causes a shift in the location. It uses this to compute the nectar amount of the novel source [3]:

$$X'_{ab} = X_{ab} + \phi_{ab}(X_{ab} - X_{fb}), \quad (2)$$

where  $a \in \{1, 2 \dots n\}$  and  $b \in \{1, 2 \dots D\}$  are the arbitrarily chosen indexes. Although « $f$ » variable is chosen at random, it must be distinct from « $a$ » variable, and « $D$ » represents the number of parameters to be optimized. « $ab$ » is merely an arbitrary integer between 0 and 1. « $ab$ » is in charge of the production of neighborhood food supplies.

If the new source nectar food amount is more than the previous one, observers remember this new position; otherwise, they recall the prior one, which was previously determined. In other words, when the choice operation between old and new food sources is accessible, the

hungry selection approach is performed. If the rejected source is  $X_{ab}$ , where,  $b = 1, 2 \dots D$ . The scout uses equation to discover a new food source  $X_{ab}$  using (3):

$$X_{ab} = X_{b\min} + \text{rand}(0,1) \cdot (X_{b\max} - X_{b\min}), \quad (3)$$

where  $X_{b\min}$ ,  $X_{b\max}$  are the minimum and maximum restrictions of the constraint to be optimized.

To balance exploration and exploitation procedures, the GABC method combines the working bee's search with the observer bee's search and the observer bee's search with the scout bee's search [3].

#### C. Program development for graver's 6 bus system.

The test system is used to design and simulate the proposed GABC-based transmission line planning algorithm is depicted in Fig. 1 based on graver's test system [15].

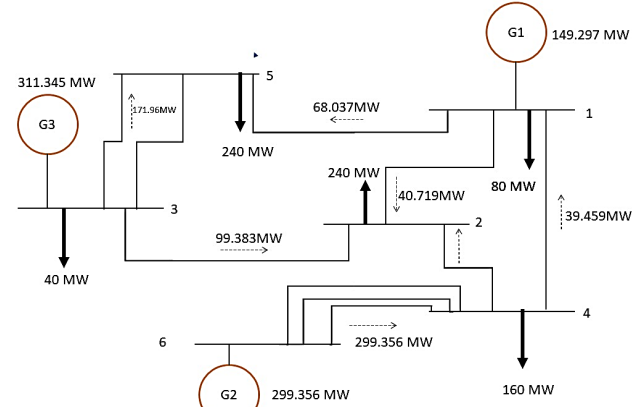

Fig. 1. Graver's 6 bus test system

The system contains 3 sources and 5 loads, each with 10 lines. The planning need is to link lines from the new generation bus 6 to the older buses 1 to 5 (Fig. 1). The objective function of transmission network expansion planning is to minimize the cost of investment through optimum value of line connection from existing bus to new bus. Minimize

$$C_{it}^k = \sum_{i,k,c} (CO_{ik} \cdot n_{ik}), \quad (4)$$

Subjected to

$$f_{ik} = P_{Gi} - P_{Di}, \quad (5)$$

$$f_{ik} - \left[ \beta_{ik} \cdot (n_{ik}^e + n_{ik}^n) \cdot (\alpha_i^e + \alpha_k^n) \right] = 0, \quad (6)$$

$$|f_{ik}| \leq (n_{ik}^e + n_{ik}^n) \cdot f_{ik}^{\max}, \quad (7)$$

$$P_{Gi}^{\max} \leq P_{Gi} \leq P_{Gi}^{\min}, \quad (8)$$

$$Q_{Gi}^{\max} \leq Q_{Gi} \leq Q_{Gi}^{\min}, \quad (9)$$

$$0 \leq n_{ik}^n \leq n_{ik}^{\max}, \quad (10)$$

where  $C_{it}^k$  is the total cost of investment in Indian rupees at new bus  $k$ ;  $CO_{ik}$  is the construction cost of one transmission line per km at  $i$ - $k$  bus;  $n_{ik}$  is the number of circuits added at each right of way;  $f_{ik}$  is the power flow between line  $i$  to  $k$ ;  $f_{ik}^{\max}$  is the maximum value of thermal reach of the line;  $P_{Gi}$ ,  $Q_{Gi}$  are real and reactive power generation at  $i$  bus;  $P_{Gi}^{\max}$ ,  $P_{Gi}^{\min}$  are the maximum and minimum possible real power generation at  $i$  bus;  $Q_{Gi}^{\max}$ ,  $Q_{Gi}^{\min}$  are the maximum and minimum possible reactive power generation at  $i$  bus;  $n_{ik}^n$ ,  $n_{ik}^{\max}$  are the number of existing line and maximum possible line to be added;  $\beta_{ik}$  is the susceptance value between  $i$  and  $k$  bus.

**Proposed algorithm.** Figure 2 depicts the suggested algorithm's flowchart, which employs (1) – (3) to compute an optimum link from new bus 6 to the current system's old buses.

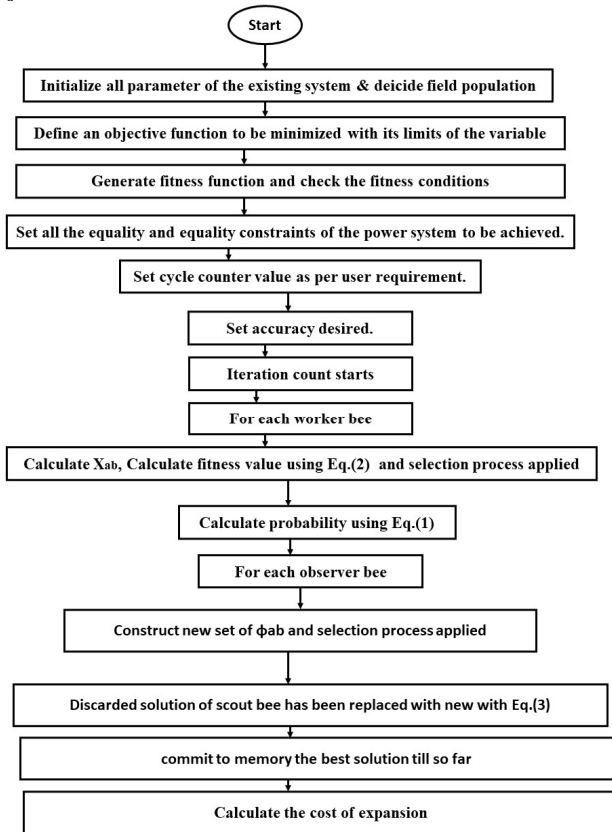

Fig. 2. Flowchart of proposed algorithm

Initially proposed program asked system data from users. It also gives option of desired speed by selecting number of iteration and desired accuracy. GABC is program such way that it improves the global minimum after each iteration. Once the global minimum achieve considering all the constrained from (5)–(10). The algorithm calculates the minimized cost using (4) once  $n_{ik}$  is calculated.

Prior to developing the TNP software for the 6-bus system. It is necessary to use a fundamental mathematical

function with a known value to evaluate the accuracy of the developed programmed [12].

Consider an example equation with a known minimum solution and constrained of it. Initially, program was ran for 2000 colonies and 1000 iterations for the function below, minimize,

$$f(x) = x^2. \quad (11)$$

Subject to,

$$-1 \leq x \leq 1. \quad (12)$$

For function of (11) and constrained of (12), the minimum is known as  $x = 0$  and program achieves the same results, which is shown in Table 1.

Table 1

Accuracy of developed program		
Function $f(x): x^2 = 0$ , where $-1 \leq x \leq 1$		
Function is to be minimize	Actual minima	Program give the minima
	0	$2.3762 \cdot 10^{-4}$

**Results of program of TNP of 6-bus system.** The 6-bus data is input to program (Fig. 1). The line power constraints are taken into account. Table 2 displays the results, which suggests that from bus 6 to 1, one line and from bus 6 to bus 2, two lines are recommended as per program. It also suggests 2 lines from bus 6 to bus 5 in order to get optimized cost. It is obvious that as the number of iterations increases, the accuracy falls, meaning that the more you iterate, the better the accuracy. It is also critical to recognize that the outcome includes more of the no colony [10].

Table 2

Final program results		
From new generation bus	To old bus	Optimal line is to be connected
6	1	$1.2085 \approx 1$
6	2	2
6	3	0
6	4	0
6	5	2
6	6	0
Total new cost of planning will be added is		$R_s = 6.2501 \cdot 10^7$ (approx.)

**Load flow results.** Figure 3 shows that the newly built system based on program results is valid with power flow analysis.

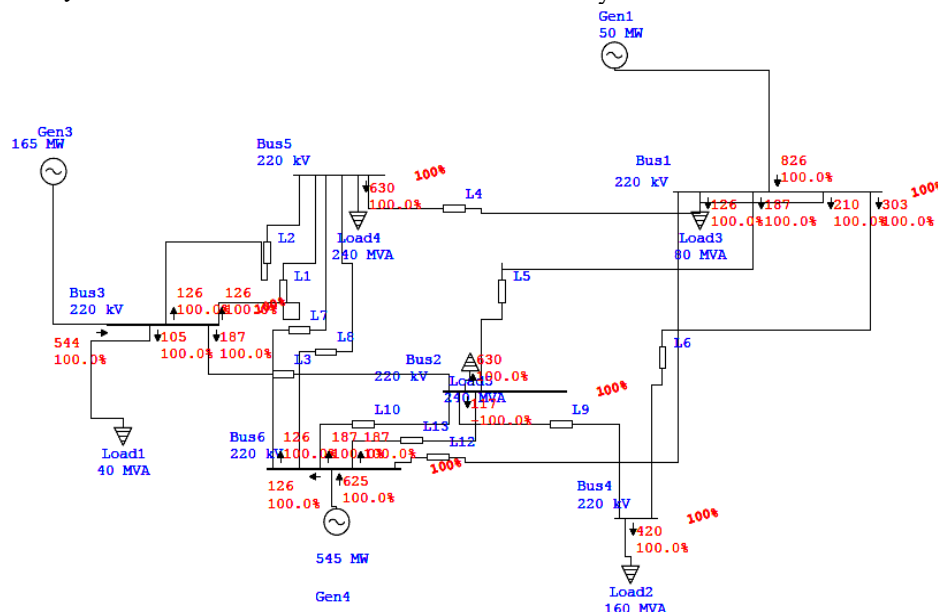

Fig. 3. Power flow results of 6-bus systems after planning

Bus voltages are within the limit. Following plans according to program, no buses are in a critical condition. Load flow also ensures that power flow from the lines is limited and that all inequality and equality restrictions are met after planning using the load flow summary presented in Table 3. The overall mismatch is 0, indicating that limitations have been met and load flow has been successful.

Table 3  
Summary of total generation, loading and demand of load flow analysis

Bus	MW	MVAr	MVA	Power factor, %
Swing bus	760	0.08	760	100 lagging
Generators	0	0.109	0.109	0 lagging
Total demand	760	760	760	100 lagging
Total mismatch = 0 MW				

**Comparison with other PSO methods** In this section, the comparison of the proposed GABC based method is compared with ABC method for same problem. Table 4 shows the comparison in terms of computation time consumed, accuracy, exploration of new line, exploitation of achieve results and minimized cost achieve through ABC and GABC.

Table 4  
GABC compare with ABC for TLEP problem solution

Parameters	Conventional ABC	GABC
Computational time, s	1	0.8
Accuracy	Less accurate	More accurate
Exploration of results	Good	Good
Exploitation	Poor	Improved
Minimized cost	10.5 % cost more than GABC	10.5 % less cost than ABC

**Conclusions.** When the system's issues are nonlinear and depend on more than one parameter, artificial intelligence approaches come in handy. The planning problem taken in this work can be handled using the Global Best Artificial Bee Colony approach, and load flow results in decision-making can be done with less effort under load uncertainty. The adoption of program and load flow analysis can improve power engineering capability, save planning time, and increase planning accuracy. The nonlinear issue of transmission line planning is not only addressed, but can also be tested and implemented in a real power system using a combined method of artificial intelligence and load flow analysis.

**Conflict of interest.** The author declares no conflict of interest.

#### REFERENCES

- Desai J.P. Analysis of Power Swings and Blackouts. 2021 *IEEE Congreso Estudiantil de Electrónica y Electricidad (INGELECTRA)*, 2021, pp. 1-6. doi: <https://doi.org/10.1109/INGELECTRA54297.2021.9748070>.
- Seifi H., Sepasian M.S. *Electric Power System Planning: Issues, Algorithms and Solutions*. Springer Science & Business Media, 2011.
- Rathore C., Roy R. Load uncertainty based transmission network expansion planning. *2013 3rd International Conference*

- on *Electric Power and Energy Conversion Systems*, 2013, pp. 1-6. doi: <https://doi.org/10.1109/EPECS.2013.6713034>.
- Mahdad B., Srairi K. Interactive artificial ecosystem algorithm for solving power management optimizations. *Electrical Engineering & Electromechanics*, 2022, no. 6, pp. 53-66. doi: <https://doi.org/10.20998/2074-272X.2022.6.09>.
- Mehdi M.F., Ahmad A., Ul Haq S.S., Saqib M., Ullah M.F. Dynamic economic emission dispatch using whale optimization algorithm for multi-objective function. *Electrical Engineering & Electromechanics*, 2021, no. 2, pp. 64-69. doi: <https://doi.org/10.20998/2074-272X.2021.2.09>.
- Desai J.P. Three-Terminal Transmission Line Protection By Considering Effect of Infeed Current. *Journal of The Institution of Engineers (India): Series B*, 2022, vol. 103, no. 6, pp. 2165-2175. doi: <https://doi.org/10.1007/s40031-022-00795-7>.
- Razavi S.E., Arefi A., Ledwich G., Nourbakhsh G., Smith D.B., Minakshi M. From Load to Net Energy Forecasting: Short-Term Residential Forecasting for the Blend of Load and PV Behind the Meter. *IEEE Access*, 2020, vol. 8, pp. 224343-224353. doi: <https://doi.org/10.1109/ACCESS.2020.3044307>.
- Garver L. Transmission Network Estimation Using Linear Programming. *IEEE Transactions on Power Apparatus and Systems*, 1970, vol. PAS-89, no. 7, pp. 1688-1697. doi: <https://doi.org/10.1109/TPAS.1970.292825>.
- Gao W., Liu S., Huang L. A global best artificial bee colony algorithm for global optimization. *Journal of Computational and Applied Mathematics*, 2012, vol. 236, no. 11, pp. 2741-2753. doi: <https://doi.org/10.1016/j.cam.2012.01.013>.
- Saif U., Guan Z., Zhang L., Mirza J., Lei Y. Hybrid Pareto artificial bee colony algorithm for assembly line balancing with task time variations. *International Journal of Computer Integrated Manufacturing*, 2017, vol. 30, no. 2-3, pp. 255-270. doi: <https://doi.org/10.1080/0951192X.2016.1145802>.
- Desai J., Makwana V. Power Swing Blocking Algorithm based on Real and Reactive Power Transient Stability. *Electric Power Components and Systems*, 2020, vol. 48, no. 16-17, pp. 1673-1683. doi: <https://doi.org/10.1080/15325008.2021.1906794>.
- Desai J.P., Makwana V.H. A novel out of step relaying algorithm based on wavelet transform and a deep learning machine model. *Protection and Control of Modern Power Systems*, 2021, vol. 6, no. 1, art. no. 40. doi: <https://doi.org/10.1186/s41601-021-00221-y>.
- Aoyang H., Shengqi Z., Xuehui J., Zhisheng Z. Short-term Load Forecasting Model Based on RBF Neural Network Optimized by Artificial Bee Colony Algorithm. *2021 IEEE 2nd International Conference on Big Data, Artificial Intelligence and Internet of Things Engineering (ICBAIE)*, 2021, pp. 486-489. doi: <https://doi.org/10.1109/ICBAIE52039.2021.9390043>.
- Bozogullarindan E., Bozogullarindan C., Ozturk C. Transfer Learning in Artificial Bee Colony Programming. *2020 Innovations in Intelligent Systems and Applications Conference (ASYU)*, 2020, pp. 1-7. doi: <https://doi.org/10.1109/ASYU50717.2020.9259801>.
- Mínguez R., García-Bertrand R., Arroyo J.M. Adaptive Robust Transmission Network Expansion Planning using Structural Reliability and Decomposition Techniques. *Computational Engineering, Finance, and Science*, 2015, 12 p. doi: <https://doi.org/10.48550/arXiv.1501.06613>.

Received 16.11.2022

Accepted 20.01.2023

Published 01.09.2023

Jigneshkumar P. Desai<sup>1</sup>, PhD, Assistant Professor,

<sup>1</sup> Electrical Engineering Department,

U.V. Patel College of Engineering, Ganpat University, India,

e-mail: Jpd.fetr@gmail.com (Corresponding Author)

#### How to cite this article:

Desai J.P. Transmission line planning using global best artificial bee colony method. *Electrical Engineering & Electromechanics*, 2023, no. 5, pp. 83-86. doi: <https://doi.org/10.20998/2074-272X.2023.5.12>