

Y. Lahiouel, S. Latreche, M. Khemliche, L. Boulemzaoud

Photovoltaic fault diagnosis algorithm using fuzzy logic controller based on calculating distortion ratio of values

Introduction. The efficiency of solar energy systems in producing electricity in a clean way. Reliance on it in industrial and domestic systems has led to the emergence of malfunctions in its facilities. During the operating period, these systems deteriorate, and this requires the development of a diagnostic system aimed at maintaining energy production at a maximum rate by detecting faults as soon as possible and addressing them. **Goal.** This work proposes the development of an algorithm to detect faults in the photovoltaic system, which based on fuzzy logic. **Novelty.** Calculate the distortion ratio of the voltage and current values resulting from each element in the photovoltaic system and processing it by the fuzzy logic controller, which leads to determining the nature of the fault. **Results.** As show in results using fuzzy logic control by calculating the distortion ratio of the voltage and current detect 12 faults in photovoltaic array, converter DC-DC and battery. References 20, table 5, figures 16.

Key words: photovoltaic system, fault diagnosis, distortion ratio of voltage and current, fuzzy logic controller.

Вступ. Ефективність систем сонячної енергії у виробництві електроенергії у чистий спосіб. Опора на нього в промислових та побутових системах призвела до виникнення несправностей у його об'єктах. У період експлуатації ці системи зношуються, і це вимагає розробки системи діагностики, спрямованої на підтримку вироблення енергії на максимальному рівні за рахунок якнайшвидшого виявлення несправностей та їх усунення. **Мета.** У цій роботі пропонується розробка алгоритму виявлення несправностей у фотоелектричній системі, що ґрунтується на нечіткій логіці. **Новизна.** Розрахувати коефіцієнт спотворення значень напруги та струму з кожного елемента фотоелектричної системи та обробити його контролером нечіткої логіки, що призводить до визначення характеру несправності. **Результати.** Як показують результати, використання нечіткого логічного управління шляхом розрахунку коефіцієнта спотворення напруги та струму дозволяє виявити 12 несправностей у фотоелектричній батареї, DC-DC перетворювачі та акумуляторі. Бібл. 20, табл. 5, рис. 16.

Ключові слова: фотоелектрична система, діагностика несправностей, коефіцієнт спотворення напруги та струму, контролер з нечіткою логікою.

Introduction. The significant increase in global energy consumption along with concerns about the environmental impacts of conventional energies has led the world to gradually move towards renewable energy sources such as solar energy, wind energy and geothermal energy. Photovoltaic (PV) is arguably the most direct way to take advantage of solar energy and is considered the most promising way to harness this energy [1]. It is very popular globally due to its advantages such as abundance, ease of installation, quiet operation, and low cost compared to other renewable energy sources; which led to its enjoyment of a great level of interest in scientific research [2].

PV installation consists of several parts where the PV panels are the main component. The latter is exposed to many environmental and electrical influences that lead to the occurrence of many faults and malfunctions. These faults directly affect the performance of the system and may lead to its failure or even the risk of incidents [3]. Some critical faults need to be quickly detected and treated to ensure healthy performances of the system. Therefore, PV panels require several maintenance operations in order to reach the optimal system performances and expand their lifespan [4]. As any industrial system, the goal is to reach the maximum energy production with minimum maintenance costs.

Several researches have studied the properties of PV modules under unusual conditions and have proposed relatively accurate and intelligent fault diagnosis and detection solutions based on neural networks and fuzzy logic algorithms, etc. [5].

There are research works that talked about this method, we mention the most important:

In [6] the authors present a DC side short circuit fault detection scheme for PV arrays consisting of multiple PV panels connected in a series/parallel configuration. The proposed fault detection scheme is based on a pattern recognition approach that uses a multi-resolution signal decomposition technique to extract the necessary features, based on determined by the fuzzy inference system if a fault occurs.

In [7] authors talk about the development of failure detection routines (FDRs) that operate on acquired datasets of grid-connected PV systems in order to diagnose the occurrence of failures. The developed FDRs consist of a failure detection and classification phase. More precisely, the failure detection phase was based on a comparative statistic between simulated and measured electrical measurements. In parallel, a fuzzy logic inference was performed in order to analyze the failure model and the exact classification of the error that occurred. The fuzzy rule-based classification system models were constructed for each failure through a supervisory learning process.

In [8] the authors have classified faults for the PV module based on artificial intelligence technology. They applied fuzzy logic to evaluate the critical fault of the PV module, according to its arrangement. The fault probabilities of the PV module are expressed by linguistic variables. The technique of consistency agreement method was used to compile the mysterious number, which was set by experts.

In [9] the authors suggested analyzing 2580 PV modules affected by different types of hotspot, as these PV modules are operated under different environmental

conditions, distributed across the UK. And then it detects the fault. The fault-finding model incorporates a fuzzy inference system using a Mamdani fuzzy controller including 3 input parameters: percentage of power loss, short circuit current (I_{sc}), and open circuit voltage (V_{oc}) in order to test the effectiveness of the proposed algorithm.

In [10] the researchers propose a technique for detecting the partial shading using the measured values for array voltage, array current, and radiation. Fuzzy logical technique (Sugeno) is presented for to detect the diagnosis partial and to classify and identify these defects, and is designed to take appropriate corrective actions.

The **goal** of this paper is the development of an intelligent fault diagnostic algorithm based on Fuzzy Logic Control (FLC) for PV installations. The fault detection initially uses simulated I-V curve estimation along with current and voltage output values from the transformer and battery. A standard test is used to differentiate between the sets of parameters calculated on the basis of various operating conditions. The proposed diagnostic method can detect and classify each specific type of fault and also deals with noise and disturbances. Modelling and diagnostic procedure were developed under MATLAB/Simulink environment.

PV system modeling. PV cells have a complex relationship between their working environment and the energy they produce. In order to adapt the generated power to the load, it is necessary to install a static DC-DC converter as an intermediate stage between the PV generator and the load. This stage is generally controlled by a Maximum Power Point Tracker (MPPT), which makes the system permanently works at its maximum power [11]. The typical architecture of a PV installation is shown in Fig. 1.

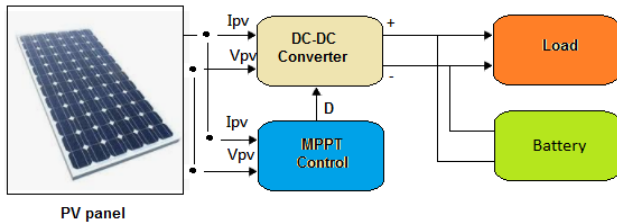

Fig. 1. Typical PV installation

PV cell modeling can be developed from its equivalent electrical circuit. The one-diode model which is also known as five-parameter model is the most commonly used. This model is a combination of a current source I_{ph} , a diode VD , a shunt resistor R_{sh} and a series resistor R_s represents the power losses [12]. The equivalent circuit for this model is illustrated in Fig. 2.

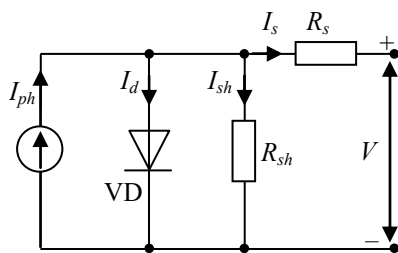

Fig. 2. One-diode PV cell model

The mathematical representation of the one-diode electrical circuit is given by the following equations:

$$I = I_{ph} - I_0 \cdot \left[\exp\left(\frac{q(V + I \cdot R_s)}{n \cdot K \cdot N_s \cdot T}\right) - 1 \right] - I_{sh}; \quad (1)$$

$$I_{ph} = I_{sc} + K_i \cdot (T - 298) \cdot \frac{G}{1000}; \quad (2)$$

$$I_0 = I_{rs} \cdot (T/T_n)^3 \cdot \exp\left[\frac{q \cdot E_{g0} \cdot (1/T_n - 1/T)}{n \cdot K}\right]; \quad (3)$$

$$I_{rs} = \frac{I_{sc}}{\exp\left(\frac{q \cdot V_{oc}}{n \cdot K \cdot N_s \cdot T}\right) - 1}; \quad (4)$$

where I_{ph} and I_{sc} are the photocurrent and the short-circuit current, respectively; $K_i = 0.0032$ is the short-circuit current of cell at 25 °C; T is the operating temperature; $T_n = 298$ K is the normal temperature; G is the solar irradiance, W/m^2 ; $q = 1.6 \cdot 10^{-19}$ C is the electron charge; V_{oc} is the open-circuit voltage; $n = 1.3$ is the ideality factor of the diode; $K = 1.38 \cdot 10^{-23}$ J/K is the Boltzmann constant; $E_{g0} = 1.1$ eV is the band gap energy of the semiconductor; N_s is the number of cells connected in series; N_p is the number of cells connected in parallel; R_s and R_p are series and parallel resistances, respectively.

PV module characteristics. The dedicated studied system for this work is simulated under a MATLAB/Simulink environment. It is composed of 8 PV modules (2 strings). Each module produces a maximum power of 200 W at 26.4 V. The electrical characteristics of each PV module under standard test conditions are shown in Table 1. The system is also composed of a DC-DC boost converter equipped with a Perturb and Observe MPPT. The simulation is done for a constant irradiance of 1000 W/m^2 and constant temperature of 25 °C. The MATLAB/Simulink model of the simulated PV system is shown in Fig. 3. The simulated I-V and P-V curves are shown in Fig. 4.

Table 1

Electrical characteristics of simulated PV module

Maximum power P_{mp} , W	200
Voltage at maximum power V_{mp} , V	26.4
Current at maximum power I_{mp} , A	7.58
Open-circuit voltage V_{oc} , V	32.9
Short-circuit voltage I_{sc} , A	8.21
Total number of cells in series N_s	54
Total number of cells in parallel N_p	1

The faults in PV systems can be temporary or permanent. Temporary faults are often caused by environmental effects such as shading and soiling. Permanent faults are usually related to PV module failures such as delamination, bubbles, yellowing, scratches and burnt cells [13]. They can be eliminated by either repairing or replacing defective modules. PV panels are also susceptible to many serious faults that can be caused by short circuits. Also, there are some other factors that can lead to productions losses such as MPPT failures, losses in wiring, defective equipment etc. However, PV system's faults can be classified based on the faulty component, such as module faults, string faults, or power grid faults [14, 15]. The most common PV systems faults are described in Table 2.

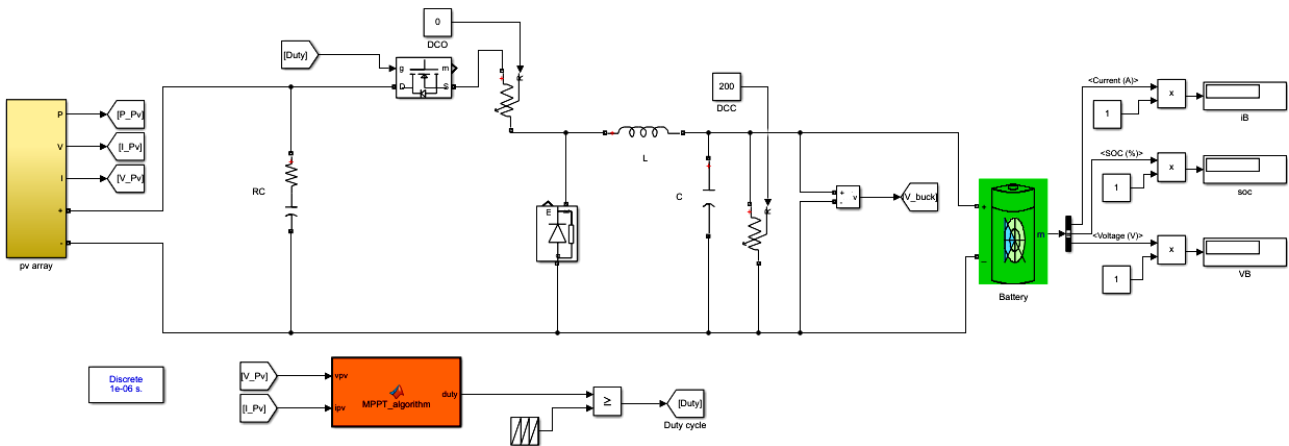

Fig. 3. MATLAB/Simulink model of the simulated PV system

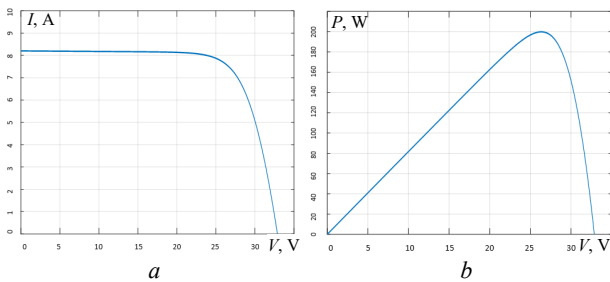

Fig. 4. $I-V$ (a) and $P-V$ (b) characteristics

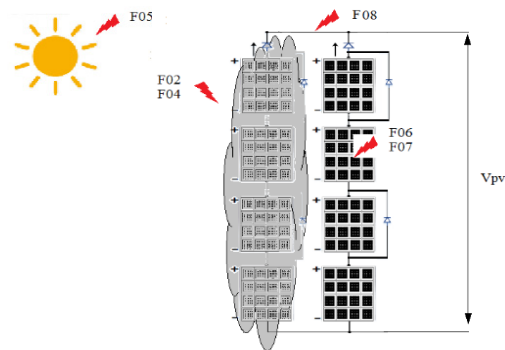

Fig. 5. PV array faults

Table 2

Faults occurring in the examined PV system

Components	Faults	Fault code
PV array	Less than 50 % total shading	F01
	Less than 50 % partial shading	F02
	More than 50 % total shading	F03
	More than 50 % partial shading	F04
	Temperature increase	F05
	Series resistances	F06
	Shunt resistances	F07
	Interconnection faults	F08
Converter DC-DC	Open circuit	F09
	Short circuit	F10
	MP controller failure	F11
Battery	Charging failure	F12

PV array faults can be divided into several groups depending on their type where there is a failure of the PV panel, cables or failure of external factors [16]. This work focuses only on faults related to the PV panel. In this stage we can talk about shading patterns whether it is total (F01, F03) or partial (F02, F04) or faults related to temperature (F05). In the other hand, PV power degradation can be caused by the increase of the resistance between the units which can be caused by corrosion, water vapor or other related factors (F06, F07). Also, interconnection faults (F08) such as short-circuit are occurred due to faulty cable's insulation or mechanical damage. Different types of PV array faults are shown in Fig. 5. The effect of each type of described faults on the generated power curve compared with ideal working conditions is illustrated in Fig. 6, 7.

DC-DC converter faults. DC-DC converters are used in PV systems in order to charge batteries and also supply DC loads [17].

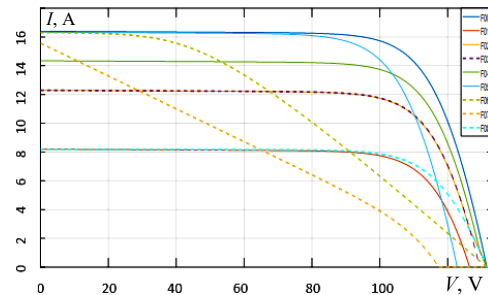

Fig. 6. $I-V$ characteristic of PV faults

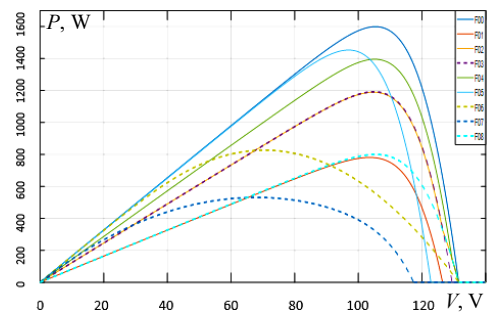

Fig. 7. $P-V$ characteristic of PV faults

While linear DC-DC converters maintain DC current flow of their input to the load, switching converters regulate the current flow by chopping the input voltage and controlling the average current flow by varying the ratio cycle. Open circuit faults (F09) refer to disconnection faults in converter circuits. Diagnosis can be done by the inspection of voltage and current indication. In the same way as open-circuit faults, short circuit faults (F10) can also occur in different types of converters. Also, the different types of MPPTs [18] used

to control the converter can also provide system faults such as command fault (F11). The different types of a buck converter related faults and its impact on the output voltage are respectively shown in Fig. 8, Fig. 9.

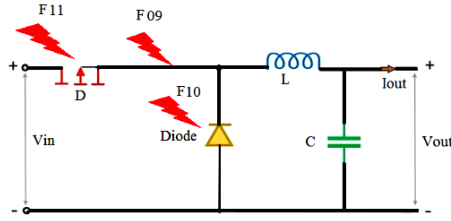

Fig. 8. Buck converter faults

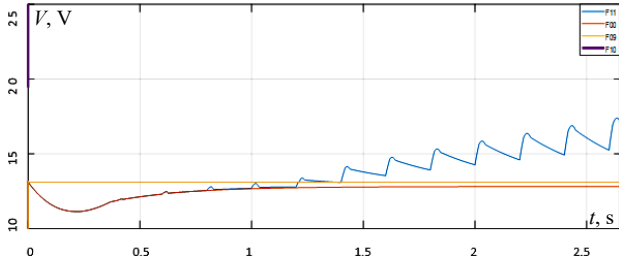

Fig. 9. Impact of faults on buck converter output

Battery faults. When PV production exceeds consumption, the excess of energy is stored in batteries. The stored energy is then used when the consumption rate exceeds production. These batteries are prone to failures such as charging failure (F12) which will be discussed in this article. The effect of batteries charging fault comparing to normal conditions is shown in Fig. 10.

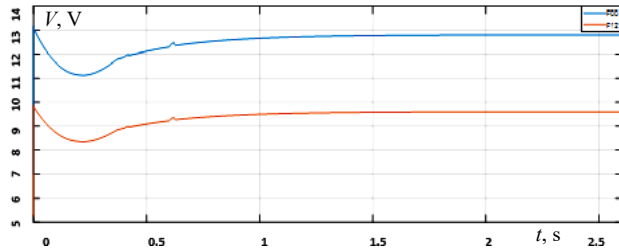

Fig. 10. Battery voltage with charging fault

Fuzzy diagnostic for PV system. The fuzzy logic approach simulates how a person makes decisions to control the problem faster. This logic helps reduce complexity by allowing information to be used in a meaningful way. Its implementation can be software, hardware or a combination of both. In general, the operating procedure of a fuzzy system is accomplished in three steps [19]. The first step is fuzzification, which is the transformation of variables into fuzzy variables which are also called linguistic fuzzy variables. The second step is called fuzzy inference. It is the construction of rules and results based on linguistic variables, using the IF-THEN statement. The last step is the defuzzification phase, which is the transition from a linguistic result to a numerical result.

FLC is one of the modern artificial intelligent techniques used in fault diagnosis in PV systems. The first step is to specify the required input and output values (net data) and their ranges. Next, the net data have to be converted into membership values (fuzzification). After that, the output membership values are synthesized based on extended fuzzy rules (fuzzy inference). Finally, the output membership values are converted into proper output values (defuzzification).

This article proposes a new intelligent technique based on Takagi-Sugeno type fuzzy logic to diagnose and identify faults in the PV generator, buck converter and battery charging failures. This technique is chosen because of its tolerance to imprecise data. It suffices to adjust the inputs/outputs of the system and call the fuzzy rules to improve detection [20]. The diagram block shown in Fig. 11 summarizes the proposed technique.

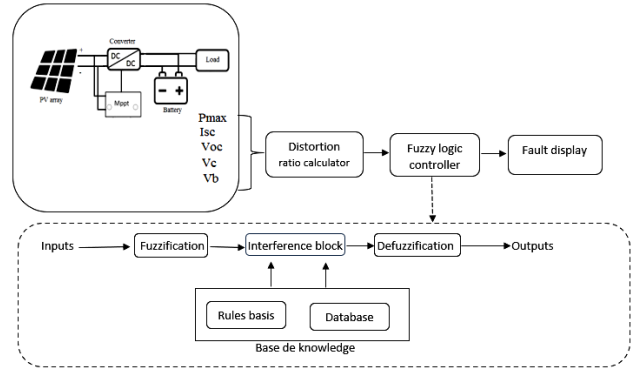

Fig. 11. General structure of a fuzzy system

The fault diagnosis technique used is based on F00 reference values (no fault) and simulated fault values. All cases are discussed and detected. The analysis of the main attributes of the $I-V$ and $P-V$ characteristics of the PV array plays the main role to accurately locate the faults in which the open-circuit voltage (V_{oc}), short-circuit voltage (I_{sc}) and maximum power (P_{max}) values have been identified to detect different types of faults. In the other hand, converter output voltage (V_c), battery output voltage (V_b) were used to determine the region where the faults occurred in the converter and battery output voltage. Then, the distortion rate I_i of all values is calculated as:

$$I_i = 1 - \frac{val_{cal}}{val_{ref}} ; \quad (5)$$

where val_{cal} is the calculated value; val_{ref} is the reference value. The result of distortion rate has to be between 0 and 1 and it is used in FLC.

FLC algorithm is based on the comparison of 5 parameters (P_{max} , V_{oc} , I_{sc} , V_c , V_b) with its reference's values. Reference values of mentioned parameters of each faulty case are illustrated in Table 3.

Table 3

Reference values of FLC for each faulty case

Faults	P_{max} , W	I_{sc} , A	V_{oc} , V	V_c , V	V_b , V
F00	1599	16.4	132	21.65	12.8
F01	780.8	8.199	126.5	26.15	12.8
F02	1189	12.3	132	21.67	12.8
F03	1192	12.3	129	21.66	12.8
F04	1395	14.35	132	21.65	12.8
F05	1453	16.33	123.2	21.9	12.8
F06	826.5	16.32	132	22.63	12.8
F07	530.6	15.58	117	26.15	12.8
F08	799.5	8.199	132	21.65	12.8
F09	1599	16.4	132	12.8	12.8
F10	0.9728	16.4	132	infini	indefined
F11	1599	16.4	132	17.2	12.8
F12	1599	16.4	132	12.8	9.7

Each region of values represents a failure case that could occur in the PV system. In the case of a faulty parameter the algorithm tends to send an alarm. When

increasing the PV installations, it is sufficient to increase the number of sensors so that we can monitor all the signals of the panels. The flowchart of the proposed fuzzy logic algorithm is shown in Fig. 12.

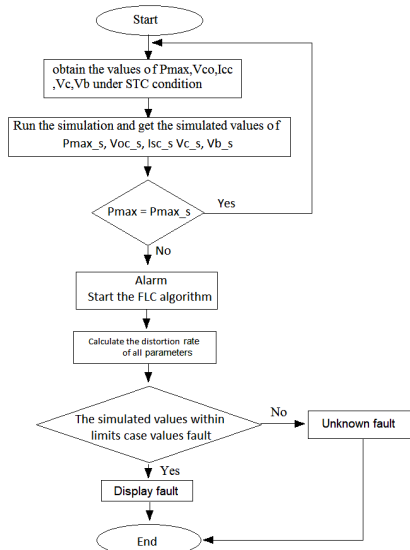

Fig. 12. Flowchart of the proposed FLC fault detection and diagnosis method

Each membership function is calculated on the base of Table 4 values with the calculated I_i values.

Table 4

Distortion rate of all parametric for each faulty case

Fault	Distortion rate of P_{max}	Distortion rate of I_{sc}	Distortion rate of V_{oc}	Distortion rate of V_c	Distortion rate of V_b
F00	0	0	0	0	0
F01	0.511694809	0.500060976	0.041666667	-0.207852194	0
F02	0.256410256	0.25	0	-0.000923788	0
F03	0.254534084	0.25	0.022727273	-0.000461894	0
F04	0.127579737	0.125	0	0	0
F05	0.091307067	0.004268293	0.066666667	-0.011547344	0
F06	0.483114447	0.004878049	0	-0.045265589	0
F07	0.668167605	0.05	0.113636364	-0.207852194	0
F08	0.5	0.500060976	0	0	0
F09	0	0	0	0.408775982	0
F10	0.99939162	0	0	-infini	indefini
F11	0	0	0	0.205542725	0
F12	0	0	0	0.408775982	0.2421875

The membership functions are depended on the mathematical calculation of the examined PV system. The fuzzy logic system is based on If-Then statement. The diagram of the proposed FLC for fault detection is illustrated in Fig. 13.

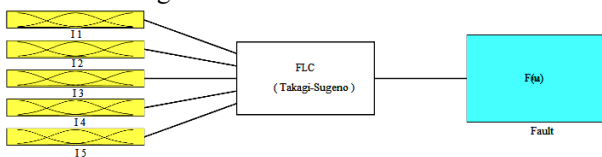

Fig. 13. Five inputs single output Takagi-Sugeno FLC proposed system

If distortion rate of P_{max} is less than 0.3, then we consider it as small.

If distortion rate of P_{max} is greater than 0.6, then we consider it as big.

If distortion rate of P_{max} is between 0.3 and 0.6, then we consider it as middle.

We now translate this human language to fuzzy logic fuzzification (distortion rate of P_{max} , small) = $\mu_{small}(P_{max})$

fuzzification (distortion rate of P_{max} , middle) = $\mu_{middle}(P_{max})$
 fuzzification (distortion rate of P_{max} , big) = $\mu_{big}(P_{max})$.

For example:

If distortion rate of $P_{max} = 0.127579737$; then
 fuzzification (distortion rate of P_{max} , small) = $\mu_{small}(P_{max}) = 1$
 fuzzification (distortion rate of P_{max} , middle) = $\mu_{middle}(P_{max}) = 0$
 fuzzification (distortion rate of P_{max} , big) = $\mu_{big}(P_{max}) = 0$.

If distortion rate of $P_{max} = 0.668167605$; then
 fuzzification (distortion rate of P_{max} , small) = $\mu_{small}(P_{max}) = 0$
 fuzzification (distortion rate of P_{max} , middle) = $\mu_{middle}(P_{max}) = 0.5$
 fuzzification (distortion rate of P_{max} , big) = $\mu_{big}(P_{max}) = 0.5$.

If distortion rate of $P_{max} = 0.99939162$; then
 fuzzification (distortion rate of P_{max} , small) = $\mu_{small}(P_{max}) = 0$
 fuzzification (distortion rate of P_{max} , middle) = $\mu_{middle}(P_{max}) = 0$
 fuzzification (distortion rate of P_{max} , big) = $\mu_{big}(P_{max}) = 1$.

The membership functions in this study are shown in Fig. 14.

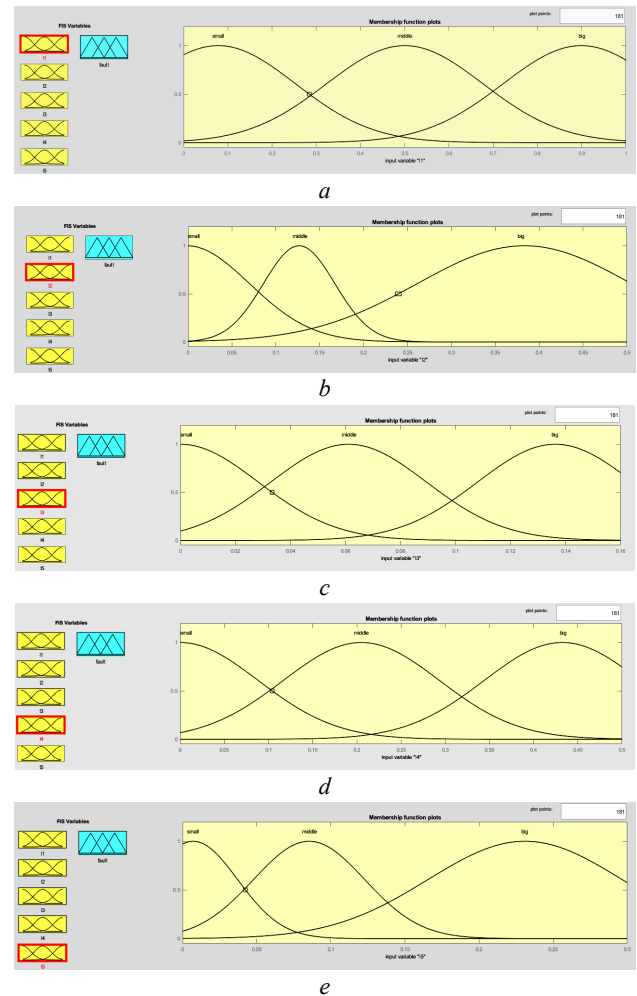

Fig. 14. Fuzzy logic system inputs:

- a) $I_1(P_{max})$; b) $I_2(I_{sc})$; c) $I_3(V_{oc})$; d) $I_4(V_c)$; e) $I_5(V_b)$

After the fuzzy variables and membership functions have been defined. The next step is to define If-Then logic inference.

For example, if the distortion rate of P_{max} is middle, the distortion rate of I_{sc} is big, the distortion rate of V_{oc} is middle, the distortion rate of V_c is small and distortion rate of V_b is small, then the fault is F01 (less than 50 % total shading). We translate this logic into fuzzy logic and resume it in Table 5.

Table 5

Fuzzy logic of all parametric for each faulty case

Fault	Distortion rate of				
	P_{max}	I_{sc}	V_{oc}	V_c	V_b
F00	small	small	small	small	small
F01	middle	big	middle	small	small
F02	small	big	small	small	small
F03	small	big	middle	small	small
F04	small	middle	small	small	small
F05	small	small	middle	small	small
F06	middle	small	small	small	small
F07	big	small	big	small	small
F08	middle	big	small	small	small
F09	small	small	small	big	small
F10	big	small	small	small	middle
F11	small	small	small	middle	small
F12	small	small	small	big	big

For a fuzzy system whose end product must be brittle, the step is necessary to turn the ambiguous final aggregate result into a brittle. This step is called defuzzification.

Use the Mean of Maximum (MoM) defuzzification method for pattern recognition applications. This defuzzification method calculates the most logical result. Instead of calculating the average membership scores for the resulting linguistic terms, the MoM defuzzification method determines the typical value for the most correct resulting linguistic term.

Results. The results obtained from the proposed FLC algorithm are respectively illustrated in Fig. 14, 15. Figure 14,a-e shows 3 Gaussian membership functions for each input variable, and 12 inferred bases that can be satisfactorily generalize the fault condition product.

Figure 16 shows a set of 12 rules for different faults states. The first 5 columns are the input variables, while the last column represents the output variable from left to right. From the figure we can show that if $I_1 = 0.5$ W, $I_2 = 0.25$ A, $I_3 = 0.08$ V, $I_4 = 0.25$ V and $I_5 = 0.15$ V, then the predicted by the fuzzy logic approach PV fault is 0.965, that's to say fault D09 as shown as below:

$$\left. \begin{aligned} I_1 = 0.5 \text{ W} &\rightarrow \mu_{middle}(P_{max}) = 1; \\ I_2 = 0.25 \text{ A} &\rightarrow \mu_{big}(I_{sc}) = 1; \\ I_3 = 0.08 \text{ V} &\rightarrow \mu_{middle}(V_{oc}) = 1; \\ I_4 = 0.25 \text{ V} &\rightarrow \mu_{middle}(V_c) = 1; \\ I_5 = 0.15 \text{ V} &\rightarrow \mu_{big}(V_b) = 1; \end{aligned} \right\} \text{fault} = 0.965 = \text{D09} .$$

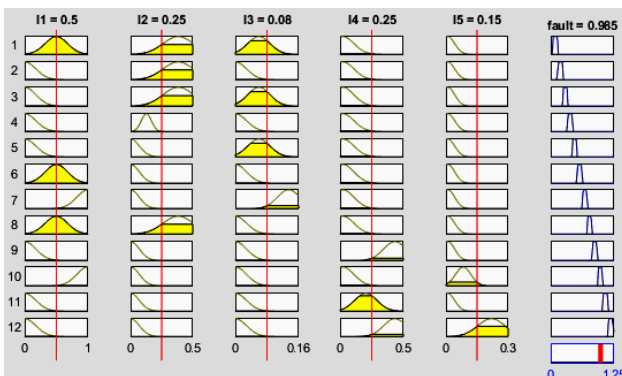

Fig. 15. Rules viewer of fuzzy logic system

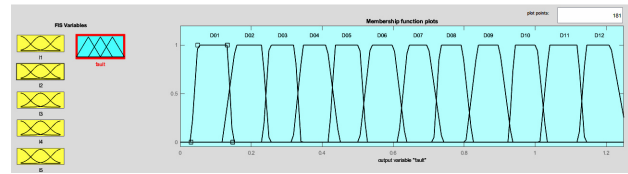

Fig. 16. Fuzzy logic system output

Conclusions. A smart technique based on Takagi-Sugeno type fuzzy logic for the diagnosis and detection of faults in a photovoltaic generator connected with a buck converter and batteries has been proposed. This technique was performed based on 5 parameter values (P_{max} , V_{oc} , I_{sc} , V_c , V_b). These values have been extracted from the analysis of the characteristics of $I-V$ and $P-V$ curves, the buck converter and the output of the batteries, followed by the extraction of all the output values such as current, voltage and power of the photovoltaic system in cases of healthy and faulty operation. 12 faults have been detected in detail in order to evaluate the performance of the proposed algorithm on the photovoltaic system.

The simulation results obtained have demonstrated the efficiency of the proposed technique. All faults have been accurately identified and classified. This technique is able to identify faults after they are detected in different components of the photovoltaic system. After all, fuzzy logic control was adopted in this study due to its high computational speed and its ability to be applicable in large-scale photovoltaic installations due to its low monitoring cost and economic benefits.

Conflict of interest. The authors declare that they have no conflicts of interest.

REFERENCES

1. Khan S.A., Mahmood T., Awan K.S. A nature based novel maximum power point tracking algorithm for partial shading conditions. *Electrical Engineering & Electromechanics*, 2021, no. 6, pp. 54-63. doi: <https://doi.org/10.20998/2074-272X.2021.6.08>.
2. Latreche S., Badoud A.E., Khemliche M. Implementation of MPPT Algorithm and Supervision of Shading on Photovoltaic Module. *Engineering, Technology & Applied Science Research*, 2018, vol. 8, no. 6, pp. 3541-3544. doi: <https://doi.org/10.48084/etasr.2354>.
3. Basnet B., Chun H., Bang J. An Intelligent Fault Detection Model for Fault Detection in Photovoltaic Systems. *Journal of Sensors*, 2020, vol. 2020, art. no. 6960328. doi: <https://doi.org/10.1155/2020/6960328>.
4. Djalab A.A., Rezaoui M.M., Mazouz L., Teta A., Sabri N. Robust Method for Diagnosis and Detection of Faults in Photovoltaic Systems Using Artificial Neural Networks. *Periodica Polytechnica Electrical Engineering and Computer Science*, 2020, vol. 63, no. 3, pp. 291-302. doi: <https://doi.org/10.3311/PPee.14828>.
5. Davarifar M., Rabhi A., Hajjaji A.El. Comprehensive Modulation and Classification of Faults and Analysis Their Effect in DC Side of Photovoltaic System. *Energy and Power Engineering*, 2013, vol. 5, no. 4, pp. 230-236. doi: <https://doi.org/10.4236/epe.2013.54B045>.
6. Yi Z., Etemadi A.H. Fault Detection for Photovoltaic Systems Based on Multi-Resolution Signal Decomposition and Fuzzy Inference Systems. *IEEE Transactions on Smart Grid*, 2017, vol. 8, no. 3, pp. 1274-1283. doi: <https://doi.org/10.1109/TSG.2016.2587244>.
7. Livera A., Theristis M., Makrides G., Georghiou G.E. On-line failure diagnosis of grid-connected photovoltaic systems based on fuzzy logic. *2018 IEEE 12th International Conference*

- on Compatibility, Power Electronics and Power Engineering (CPE-POWERENG 2018), 2018, pp. 1-6. doi: <https://doi.org/10.1109/CPE.2018.8372537>.
8. Perveen S., Ashfaq H., Asjad M. Fault Ranking in PV Module based on Artificial Intelligence Technique (AIT). 2019 International Conference on Power Electronics, Control and Automation (ICPECA), 2019, pp. 1-6. doi: <https://doi.org/10.1109/ICPECA47973.2019.8975619>.
9. Dhimish M., Badran G. Photovoltaic Hot-Spots Fault Detection Algorithm Using Fuzzy Systems. *IEEE Transactions on Device and Materials Reliability*, 2019, vol. 19, no. 4, pp. 671-679. doi: <https://doi.org/10.1109/TDMR.2019.2944793>.
10. Djalab A., Nekbil N., Laouid A.A., Kouzou A., Kadiri K. An Intelligent Technique to Diagnosis and Detection the Partial Shading Based on Fuzzy Logic for PV System. 2020 17th International Multi-Conference on Systems, Signals & Devices (SSD), 2020, pp. 235-238. doi: <https://doi.org/10.1109/SSD49366.2020.9364109>.
11. Boudaraia K., Mahmoudi H., Abbou A. MPPT Design Using Artificial Neural Network and Backstepping Sliding Mode Approach for Photovoltaic System under Various Weather Conditions. *International Journal of Intelligent Engineering and Systems*, 2019, vol. 12, no. 6, pp. 177-186. doi: <https://doi.org/10.22266/ijies2019.1231.17>.
12. Ali Moussa M., Derrouazin A., Latroch M., Aillerie M. A hybrid renewable energy production system using a smart controller based on fuzzy logic. *Electrical Engineering & Electromechanics*, 2022, no. 3, pp. 46-50. doi: <https://doi.org/10.20998/2074-272X.2022.3.07>.
13. Madeti S.R., Singh S.N. A comprehensive study on different types of faults and detection techniques for solar photovoltaic system. *Solar Energy*, 2017, vol. 158, pp. 161-185. doi: <https://doi.org/10.1016/j.solener.2017.08.069>.
14. Nebti K., Lebied R. Fuzzy maximum power point tracking compared to sliding mode technique for photovoltaic systems based on DC-DC boost converter. *Electrical Engineering & Electromechanics*, 2021, no. 1, pp. 67-73. doi: <https://doi.org/10.20998/2074-272X.2021.1.10>.
15. Mellit A., Tina G.M., Kalogirou S.A. Fault detection and diagnosis methods for photovoltaic systems: A review. *Renewable and Sustainable Energy Reviews*, 2018, vol. 91, pp. 1-17. doi: <https://doi.org/10.1016/j.rser.2018.03.062>.
16. Latreche S., Khenfer A., Khemliche M. Sensors placement for the faults detection and isolation based on bridge linked configuration of photovoltaic array. *Electrical Engineering & Electromechanics*, 2022, no. 5, pp. 41-46. doi: <https://doi.org/10.20998/2074-272X.2022.5.07>.
17. Saravanan S., Senthil Kumar R., Prakash A., Chinnadurai T., Tiwari R., Prabakaran N., Chitti Babu B. Photovoltaic array reconfiguration to extract maximum power under partially shaded conditions. *Distributed Energy Resources in Microgrids: Integration, Challenges and Optimization*, 2019, pp. 215-241. doi: <https://doi.org/10.1016/B978-0-12-817774-7.00008-9>.
18. Abbes H., Abid H., Loukil K., Toumi A., Abid M. Etude comparative de cinq algorithmes de commande MPPT pour un système photovoltaïque. *Revue des Énergies Renouvelables*, 2014, vol. 17, no. 3, pp. 435-445. (Fra).
19. Abdel-Maksoud H., Khater M., Shaaban S. Adaptive Fuzzy Logic PI Control for Switched Reluctance Motor Based on Inductance Model. *International Journal of Intelligent Engineering and Systems*, 2017, vol. 10, no. 4, pp. 41-49. doi: <https://doi.org/10.22266/ijies2017.0831.05>.
20. Marhraoui S., Abbou A., Cabrane Z., Rhaili S., Hichami N. Fuzzy Logic-Integral Backstepping Control for PV Grid-Connected System with Energy Storage Management. *International Journal of Intelligent Engineering and Systems*, 2020, vol. 13, no. 3, pp. 359-372. doi: <https://doi.org/10.22266/ijies2020.0630.33>.

Received 18.09.2022

Accepted 19.11.2022

Published 01.07.2023

Younes Lahiouel¹, PhD Student,
 Samia Latreche¹, Doctor of Technical Science, Associate Professor,
 Mabrouk Khemliche¹, Doctor of Technical Science, Professor,
 Lokmane Boulemzaoud¹, PhD Student,
¹ Technology Faculty, Electrical Engineering Department,
 Automation Laboratory of Setif, University of Setif 1, Algeria,
 e-mail: lahiouelyounes@gmail.com (Corresponding Author);
 ksamia2002@yahoo.fr; mabroukkhemliche@univ-setif.dz;
 lokmane@outlook.com

How to cite this article:

Lahiouel Y., Latreche S., Khemliche M., Boulemzaoud L. Photovoltaic fault diagnosis algorithm using fuzzy logic controller based on calculating distortion ratio of values. *Electrical Engineering & Electromechanics*, 2023, no. 4, pp. 40-46. doi: <https://doi.org/10.20998/2074-272X.2023.4.06>