

N. Benchouia, M. Saaidia

OPTIMIZATION AND RELIABILITY OF THE POWER SUPPLY SYSTEMS OF A COMPRESSOR STATION

As gas pipeline systems become larger and more complex, the importance of optimally operating and planning these facilities has increased. The capital costs and operating expenses of pipeline systems are so large that even small improvements in the use of the system can involve large sums of money. **Purpose.** This article proposes a method to improve the reliability and optimization of power supply systems for compressor stations. **The novelty** of the proposed work is the development of a new mathematical model that allows the choice of the most appropriate maintenance policies in the best way to significantly reduce costs as well as to optimize useful key performance indicators – failure rate, average time between breakdowns, the average repair time for equipment in compressor station electrical supply systems. Applying graph theory to represent this mathematical model from the schematic diagram of the different energy sources with respect to the five compressor stations is adequate. **Methods.** The problem that arises for the future operator or operator is, among others, how to balance two main aspects: a technical aspect and an economic aspect. The proposed methodology introduces a research algorithm to calculate the optimal values of the operating parameters of the power supply systems of compressor stations by combining technical and economic aspects in order to reduce costs and increase performance indicators. The proposed algorithm can be implemented in FORTRAN code. **Results.** The algorithm developed is an efficient tool for calculating maintenance costs and allows by means of programming to define the most appropriate maintenance policy. On the other hand, this technique could be used as an essential economic evaluation indicator for other equipment in order to choose among all the technically possible solutions the one which allow obtaining the best economic result. **Practical value.** The proposed algorithm has been examined in this third variant of the supply system with two turbogenerators. The result of the optimization shows a clear preference for selecting station C for the pipeline as this presents the minimum cost which is the definition of the algorithm optimizer. Then, it is important to adopt the most recommended maintenance policies and practices in order to ensure the availability of the power supply systems and to avoid unplanned outages with the resulting loss of production. References 12, table 2, figures 7.

Key words: power supply system, reliability, optimization, economic aspects, technical aspects, graph theory.

У міру того як газопровідні системи стають дедалі більшими та складнішими, зростає значення оптимального функціонування та планування цих об'єктів. Капітальні витрати та експлуатаційні витрати трубопровідних систем настільки великі, що навіть незначні вдосконалення у використанні систем можуть залучити великі суми грошей. **Мета.** У статті пропонується метод підвищення надійності та оптимізації систем електропостачання компресорних станцій. **Новизна** запропонованої роботи полягає у розробці нової математичної моделі, яка дозволяє найкращим чином вибрати найбільш відповідні політики технічного обслуговування, щоб значно скоротити витрати, а також оптимізувати корисні ключові показники ефективності – рівень відмов, середній час між поломками, середній час ремонту обладнання в системах електропостачання компресорної станції. Застосування теорії графів для представлення цієї математичної моделі на принциповій схемі різних джерел енергії щодо п'яти компресорних станцій є достатнім. **Методи.** Задача, яка виникає у майбутнього або діючого оператора, полягає, серед іншого, у тому, як збалансувати два основні аспекти: технічний аспект та економічний аспект. Запропонована методологія вводить алгоритм дослідження для розрахунку оптимальних значень робочих параметрів систем електропостачання компресорних станцій шляхом поєднання технічних та економічних аспектів з метою зменшення витрат та збільшення показників ефективності. Запропонований алгоритм може бути реалізований у програмі на мові програмування FORTRAN. **Результати.** Розроблений алгоритм є ефективним інструментом для розрахунку витрат на технічне обслуговування та дозволяє за допомогою програмування визначити найбільш відповідну політику технічного обслуговування. З іншого боку, цю методіку можна використовувати як важливий показник економічної оцінки для іншого обладнання, щоб вибрати серед усіх технічно можливих рішень те, яке дозволяє отримати найкращий економічний результат. **Практичне значення.** Запропонований алгоритм був перевірений у третьому варіанті системи живлення з двома турбогенераторами. Результат оптимізації показує чітку перевагу щодо вибору станції C для трубопроводу, оскільки це представляє мінімальну вартість, яка є визначенням оптимізатора алгоритму. Тоді важливо прийняти найбільш рекомендовані політики та практики технічного обслуговування, щоб забезпечити доступність систем електропостачання та уникнути незапланованих відключень із наслідком втрат виробництва. Бібл. 12, табл. 2, рис. 7.

Ключові слова: система електропостачання, надійність, оптимізація, економічні аспекти, технічні аспекти, теорія графів.

Introduction. Compressor station (CS) is an integral and an essential part of a gas pipeline, providing gas transportation by means of power equipment. It serves as a control element in the complex of buildings, belonging to the trunk gas pipeline. The pipeline operation mode is defined through the compressor station operation parameters.

Power supply system (PSS) is a combination of sources and systems of conversion, transmission and electric energy distribution. Power supply system does not usually include consumers (or electricity receivers).

The following requirements are to be met by power supply systems:

- reliability and continuity of power supply to consumers;
- quality of electric energy on consumer input;
- safety of PSS elements maintenance;
- unification (modularity, standardization);
- economic efficiency (includes such concepts as energy efficiency and energy conservation);
- ecological compatibility;
- ergonomics [1].

As natural gas pipeline systems have grown larger and more complex, the importance of optimal operation

and planning of these facilities has increased. The investment costs and operating expenses of pipeline networks are so large that even small improvements in system utilization can involve substantial amounts of money saving [2].

For electric power supply systems, intended to provide the work of processing facilities with a continuous cycle (such systems include compressor stations of trunk gas pipelines) reliability and maintainability are considered to be the main properties. Problems of durability and safety of the system are not too much crucial. For modern electrical driven, equipped with powerful synchronous motors, problems of stability and vitality of the systems and their power supply are considered to be additional important properties [1].

In a gas transmission network, the overall operating cost of the system is highly dependent upon the operating cost of the compressor stations of the network. In fact, this compressor station's operating cost is generally measured by the quantity of the consumed fuel. According to [3], the operating cost of running the compressor stations represents between 25 % and 50 % of the total company's operating budget.

Recently, the issues of reliability improvement and configuration optimization of power supply systems of industrial facilities have been gaining significance [4]. Reliability is all that is required for a product to function without failure, or with a failure frequency low enough to be acceptable in its intended use. Its conservation concerns the Maintainability which takes care of what must be done so that a product is brought back under conditions as close as possible to those foreseen at the beginning of its operation.

Many researchers have presented and described proposed optimization and reliability methods for power supply systems of a compressor station. Literature reviews have been written to summarize the methods and the achievements. In [5] authors have illustrated the different influencing factors for the economic success of a gas compression station. Important criteria include first cost, operating cost (especially fuel cost), capacity, availability, life cycle cost, and emissions. Decisions about the layout of compressor stations such as the number of units, standby requirements, type of driver and type of compressors have an impact on cost, fuel consumption, operational flexibility, emissions, as well as availability of the station. An overview of important mathematical optimization and artificial intelligence (AI) techniques used in power optimization problems. Applications of hybrid (AI) techniques have also been discussed in [6]. The statistical data on the failures of the elements of the electrical power systems for the gas pumping compressor stations is studied in [7]. The distribution functions of operating time between failures, operating time between unplanned repairs, restoration time are chosen for power supply systems' elements. Parameters of Weibull distribution function are determined. The reliability of power supply system for gas pumping compressor station is simulated. Comparative analysis of the system reliability with hot and cold reserve is processed. The role of elements and their parameters for ensuring reliability are determined.

The rational boundaries for increasing reliability for the most important system elements are determined in [7]. In [8] authors solve the reliability design problem which is a very interesting problem often encountered in the energy industry. It is formulated as a sequence of redundancy optimization problems (ROP). The resolution of this problem uses a developing Ant Colony Optimization (ACO) method. This new algorithm for choosing an optimal series-parallel power structure configuration is proposed. It minimizes the total investment cost subject to availability constraints.

However, many of the algorithms currently used by the system operators and planners are based on heuristics and have severe limitations. Therefore, optimization algorithms used during operations need to be timely in detecting problems and suggesting corrective actions.

The goal of the paper is the proposal of a tool allowing to optimize the power supply systems of a real existing compressor station, taking into account the technical aspect and the economic aspect on the basis of a mathematical model which makes it possible to increase the reliability of the entire operation of the mechanism and to considerably ensure its availability in order to minimize the total expenditure of the electrical supply system of the BISKRA station, Algeria.

Subject of investigations. This paper carries out a comprehensive study of calculation and optimization of the power supply systems of compressor stations with the essential objective of choosing among all the technically possible solutions those which allows obtaining the best economic result.

In this article, a new flexible and efficient model and an optimization algorithm is proposed in order to solve the problem of reliability, maintainability and availability of operation in order to minimize the costs of the power supply systems of natural gas compression stations.

This paper is structured as follows: in Section 2, the description of the compressor station and the technological process used in the model formulation are presented; in Section 3, a development optimization criterion is introduced; the development of the power system optimization algorithm is presented in Section 4. The results showing the graphic presentation of the calculation and the performance of the proposed formulation are presented in Section 5. Finally, in Section 6, conclusion on the achieved results is presented.

Presentation of the compressor station. In [9] the gas pipeline GK1 (40'') GK2 (42'') is designed to ensure the connection between the departure terminal of HASSI R'MEL and the arrival terminal of SKIKDA, as well as the supply of the SONELGAZ (The Algerian Electricity production and distribution company) distribution centers in eastern Algeria.

Construction of the pipeline began in 1968 for it to be commissioned in its first phase in 1971.

In its first phase, the gas pipeline ensured a flow of 5.7×10^9 m³/year with no in-line compressor station (free flow).

In its second phase and with increasing energy requirements, two compressor stations were installed (stations B and D) to achieve a flow rate of 9.2×10^9 m³/year.

In its third phase, the gas pipeline is operated with five in-line compression stations thus ensuring maximum speed with a flow rate of 12.7×10^9 m³/year.

The natural gas pipe between HASSI R'MEL and SKIKDA has a length of 574.87 km. It is designed to service at an absolute pressure of 71.05 ± 0.4 bars and a maximum temperature of 60°C over its entire length.

The departure terminal controls the inlet pressure of 71.05 ± 0.4 bars absolute of the pipe. The arrival terminal is able to maintain downstream pressure from 43 to 45 bars absolute. The annual flow from HASSI R'MEL is 12.7×10^9 m³/year (optimal conditions in summer and winter). Table 1 details the operating conditions of the five stations such as compressor suction pressure, compressor suction temperature, maximum power, etc.

Table 1 Service condition of stations

Condition \ Station	A	B	C	D	E
Compressor (in service + reserve)	3+1	3+1	3+1	3+1	3+1
Gas flow per machine (kg/h)	455.93	449.96	442.46	439.80	432.30
Compressor suction pressure (bar)	50.49	48.15	48.30	48.41	50.14
Temperature compressor suction ($^\circ\text{C}$)	38.06	44.86	43.94	44.60	40.93
Compressor cooling point (bar)	73	73	73	73	73
Compressor discharge temperature ($^\circ\text{C}$)	-	-	-	-	-
Maximum station output (bar)	71.5	71.5	71.5	71.5	71.5

Description of the technological process. The station's gas compression system begins at the filter inlet manifold located in the northeast corner of the facility site (or refers to the north of the facility, not true north).

The gas passes through vertical filters that retain moisture and filings making the gas suitable for recompression in the station compressors to the turbocompressors (TC) suction manifold.

In [9] the «A», «B», «C» and «D» turbocompressors are individually connected to this manifold. The suction line of each compressor is 60.96 cm in diameter (see Fig. 1).

The gas is sucked into the compressor or its pressure is increased to 73 bars absolute. It is discharged into the discharge manifold through the 60.96 cm discharge line of each compressor. The discharge manifold directs gas to a calibrated orifice where the rate of flow is determined. The gas then passes into the after cooler where its temperature is reduced to a value not exceeding 60°C .

From the coolers, the gas passes through the 101.6 cm mainline. The pressure losses in the gas refrigerants are 1.5 bars absolute; so at the exit of the station, we will have the extreme values of pressure and temperature which are 71.5 bars absolute and 60°C .

For this technological process to be ensured, the turbocompressors must be in good working order. So the adopted power supply system plays a key role.

According to statistical calculations, failures of fuel systems have a direct influence on the reduction of the operating time of turbochargers (restarting, fuel and oil losses, etc.). This is why the analysis of adequate feeding systems for this type of process becomes an absolute necessity.

Figure 1 shows the technological process of the compressor station. We find that failures in the power supply system directly affect the decrease in uptime of turbocompressors.

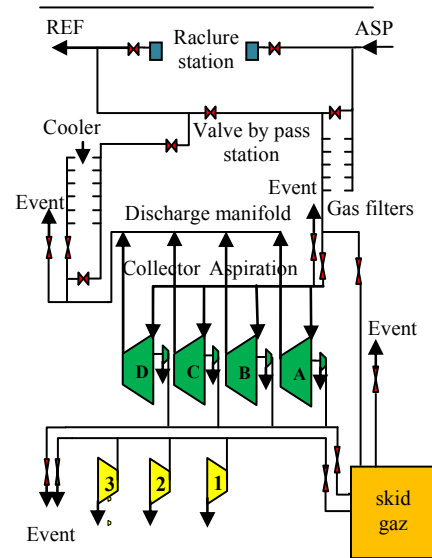

Fig. 1. Technological process of a compressor station

Proposed optimization methodology. The methodology of the proposed study is based on the calculation and optimization of the power supply systems of compressor stations on the basis of two main aspects: a technical aspect and an economic aspect.

Technical aspect. The technical aspect is the ability of the power supply system to provide the compressor station with the electrical energy of a required quality without interruption; which means to reduce the damage due to accidental failures (interruption in electrical energy) by increasing the reliability of the power supply system while maintaining the economic conditions surrounding the problem. The process of reliability evaluation may be done using two major groups of statistical indicators: λ , MTBF (Mean Time Before Failure) and MTTR (Mean Time To Repair) are the two main indicators of reliability used industrially [10].

Failure rate λ represents the failure rate or the damage rate. It characterizes the speed of variation of reliability over time for a given work period, total duration in active service

$$\lambda = \frac{\text{Total number of failures during service}}{\text{Total operating time}} \quad (1)$$

In practice, the failure rate can be constant, but also increasing or decreasing over time, with gradual change and without discontinuity.

The failure rate is the probability that an entity will lose its ability to perform a function during the interval, knowing that it has not failed between $[0, t]$; we note it:

$$\lambda(t) = \frac{1}{MTBF} \quad (2)$$

MTBF is often translated as being the average of good functioning but represents the average of the times between two failures (*TBF*):

$$MTBF = \frac{\sum TBF}{N} \quad (3)$$

where N is the number of failures.

MTTR is average time to repair which expresses the average time for repair spots. It is calculated by adding the active times maintenance as well as additional maintenance times, all divided by the number of interventions:

$$MTTR = \frac{\sum \text{intervention time for } N \text{ failures}}{N}, \quad (4)$$

repair rate μ is

$$\mu = \frac{1}{MTTR}. \quad (5)$$

Economic aspect. In the economic study comparing the different variants of the power supply system, the factors directly influenced by reliability considerations are investments (installation expenditure), on one hand, and maintenance expenses, supervision expenses, expenses due to loss of electrical power and transformers and depreciation expenses on the other hand. These expenses are called operating expenses [11].

Therefore, the solution to be adopted must minimize the total expenditure on the power supply system in question, which is given by the following formula:

$$C_t = P_n \cdot C_{inst} + C_{op} + D \rightarrow \min, \quad (6)$$

where P_n is the normative coefficient of investment efficiency; C_{inst} is the installation (capital) expenses for power system components by line; C_{op} is the operating expenses; D is the damage due to accidental power system failures.

P_n depends on the period of depreciation of the invested capital as follow:

$$P_n = \frac{1}{T_d} = 0.12, \quad (7)$$

where the period of depreciation as follows:

$$T_d = (8 \div 10), \text{ year}. \quad (8)$$

C_{inst} is given by the following formula:

$$C_{inst_l} = I_0 \cdot l, \quad (9)$$

where I_0 is the kilometric price, (DA/km, DA – Algerian Dinar) and l is the length of line, km.

For transformers:

$$C_{inst_{TR}} = N \cdot I_{TR}, \quad (10)$$

where N being the number of transformers to install and I_{TR} is the price of a processor, DA.

For turbogenerators:

$$C_{inst_{TG}} = N \cdot I_{TG}, \quad (11)$$

where N is the number of turbogenerators; I_{TG} is the price of a turbogenerator, DA.

C_{op} is given by the following formula:

$$C_{op} = C_{losses} + d_{an} + C_m, \quad (12)$$

where C_{losses} is the expenditure due to loss of electrical energy in the line and transformers, can be represented as follows:

$$C_{losses} = (\Delta w_l + \Delta w_{TR}) \cdot C_0, \quad (13)$$

where Δw_l represents the losses of electrical energy in the line:

$$\Delta w_l = \left(\frac{S_{\max}}{V_n} \right)^2 \cdot r_0 \cdot l \cdot \tau_{\max} \cdot 10^3, \quad (14)$$

where S_{\max} is the maximum apparent power passing through the line (in MVA) depending on the parameters: V_n is the electrical power transmission rating, kV; r_0 is the

specific resistance of the line, Ω/km ; l is the length of line, km; τ_{\max} is the maximum time of loss of electrical energy during one year, h/year; Δw_{TR} is the losses of electrical energy in the transformer:

$$\Delta w_{TR} = \Delta P_0 \cdot T_f + \Delta P_a \cdot K_l^2 \cdot \tau_{\max}, \quad (15)$$

where ΔP_0 is the active power losses in the magnetic circuit (not depending on load), kW; T_f is the transformer operating time during one year ($T_f = 8760$ h); ΔP_a is the active power losses in windings created by Joule effect, kW; K_l is the transformer load factor ($K_l = 0.7$); C_0 is the cost of one kilowatt hour of electrical energy, DA/kWh.

Annual depreciation expenses d_{an} to offset expenses due to wear and tear of power system components is given by the following formula:

$$d_{an} = \frac{\alpha(\%)}{100} \cdot I, \quad (16)$$

where α is the depreciation rate; it varies from one element to another (for the line $\alpha = 2.4$ %; for the transformer $\alpha = 6.4$ %; for the turbogenerator $\alpha = 6.5$); I is the clean investment; C_m is the maintenance, inspection and supervision expenses. These are directly related to the degree of reliability and safety level imposed on the power system:

$$C_m \approx 0.20 \cdot d_{an}. \quad (17)$$

Damage due to accidental power system failures D :

$$D = 1.08 \cdot \Delta w_a \cdot C_0, \quad (18)$$

where 1.08 is the reserve coefficient which takes into account the accidental downtime of less than 0.1 hours; Δw_a is the electrical energy not delivered for one year due to accidental failure of the power supply system, kW·h/year.

$$\Delta w_a = P_M \cdot 8760 \cdot Q \cdot \varepsilon \cdot \beta_m \cdot \beta_q, \quad (19)$$

where P_M is the maximum active power (calculated) of the compressor station, kW; Q is the total probability of accidental failure of two power system circuits.

Practice has shown that accidental failures follow an exponential law:

$$Q = \tau \cdot \left(1 - e^{-\lambda} \right) / 8760, \quad (20)$$

where τ is the total repair time of the power supply system expressed in hours; λ is the total failure rate of the power supply system expressed in 1/year; ε is the coefficient of the carried power limitation in the damage regime:

$$\varepsilon = \frac{P_M - P_a}{P_M}, \quad (21)$$

$$P_a = 1.4 \cdot S_{nTR} \cos \varphi, \quad (22)$$

where P_a is the allowable power of the transformer in the damage regime (in our study we considered the failure of two circuits of the power supply system, ($P_a = 0 \Rightarrow \varepsilon = 1$); β_m and β_q are respectively the filling coefficients of the monthly and daily load diagrams for a compression station: $\beta_m = 0.97$; $\beta_q = 0.94$.

Development of power system optimization algorithm. It is based on the graph theory which consists of developing a mathematical model based on the layout diagram of the different power sources compared to the five compressor stations. Figure 2 illustrates the graphic presentation of power supply system of compressor stations.

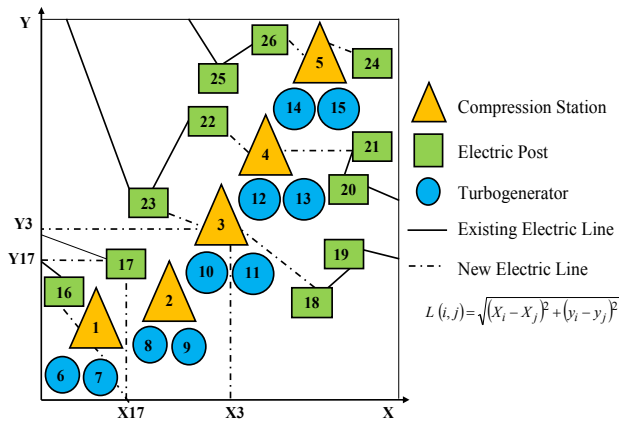

Fig. 2. Graphic presentation of power supply system of compressor stations

The power supply system is completely represented mathematically by a matrix $A(N, M)$ which determines the connection between the compressor stations and the power sources (existing power line presents in Fig. 3).

		Power sources							
Compression station	N	6	7	8	9	-	-	-	M
	1	0	1	0	0	0	0	1	0
2	1	0	0	0	1	0	0	0	0
3	0	0	1	0	0	1	0	0	0
4	0	0	0	0	0	0	0	1	1
5	0	0	0	0	0	1	1	0	0
Power sources	6	-1	0	0	-1	0	0	-1	0
	7	0	-1	0	0	-1	0	0	0
	8	0	0	-1	0	0	0	-1	0
	l	-	-	-	-	-	-	-	-
	l	-	-	-	-	-	-	-	-
	N	-	-	-	-	-	-	-	-

$$A(i, j) = \begin{cases} -1 & \text{if } (A_i, A_j) \in E(G) \text{ - points connected by an existing line} \\ 0 & \text{if } (A_i, A_j) \notin E(G) \text{ - no connections between points} \\ 1 & \text{if } (A_i, A_j) \in E(G) \text{ - points connected by a new line} \end{cases}$$

Fig. 3. The developed mathematical model of power supply system of compressor stations (where $A(i, j) = -1$ is connection between power sources (existing line); $A(i, j) = 0$ is no connection; $A(i, j) = 1$ is connection between power sources and compressor stations (new line))

Figure 4 shows the flow chart of the algorithm for optimization of n -electric power supply systems of compressor stations. It allows, in its first part, to calculate the installation and operating expenses by different variants of the power supply system and in the second part, it allows us to calculate the damage due to accidental failures by different variants of the power supply system. This allows us to choose at the same time the most optimal variant of the power supply system which total expenses will be minimal.

Calculation of reliability parameters. The 100 % confidence in electrical equipment does not exist. So the concept of reliability only gives us the degree of confidence in this equipment. It leads to studies of failure rate (λ), repair time (τ), time of proper operation, etc. It becomes the link between the technological aspect and the economical aspect [11, 12]. For this reason, the reliability of an electrical power system is the probability

This mathematical model allowed us to develop a calculation flowchart taking into account three essential conditions:

- substations (power sources) must have a reserve of electrical energy;
- a compressor station can only be powered from two power sources;
- the distance between the power source and a compressor station L must be less than the critical distance L_{CR} which depends on the nominal voltage of electric power transmission and power:

$$L(i, j) < L_{CR}, \quad (23)$$

where

$$L(i, j) = \sqrt{(X_i - X_j)^2 + (Y_i - Y_j)^2}, \quad (24)$$

where (X_i, Y_i) is the coordinates of the i^{th} electrical post or compressor station; (X_j, Y_j) is the coordinates of j^{th} the electrical post.

Optimization criteria:

$$C_t = P_n \cdot C_{inst} + C_{op} + D \rightarrow \min$$

C_t – total expenditure, DA;

P_n – normative coefficient, $P_n = 0.12$;

C_{inst} – installation expenses, DA;

C_{op} – operating expenses, DA;

$$C_{op} = C_{losses} + d_{an} + C_m$$

C_{losses} – expenses due to losses of electrical energy in lines and transformers;

d_{an} – annual depreciation expenses;

C_m – maintenance expenses, $C_m = 0.20 \cdot d_{an}$;

D – damage due to accidental failures of PSS, DA.

that it will perform its mission satisfactorily and under specified environmental conditions.

Considering reliability economically as high availability is expensive. It is certain that the cost price of the power supply system has to be increased if we want the failure rate of the system to be reduced.

Figure 5 shows the expenditure curves according to reliability. This approach attempts to determine the appropriate sums to invest in reliability is to compare the costs caused by failures (that is, the costs resulting from poor reliability) with the costs necessary to provide greater reliability. It is clear when increasing the reliability of the power system it means reducing the risk of its failure (reducing damage).

This power supply system is a set of electrical equipments belonging to the group of repairable elements. Therefore; reliability is characterized by the failure rate (λ) and repair time (τ).

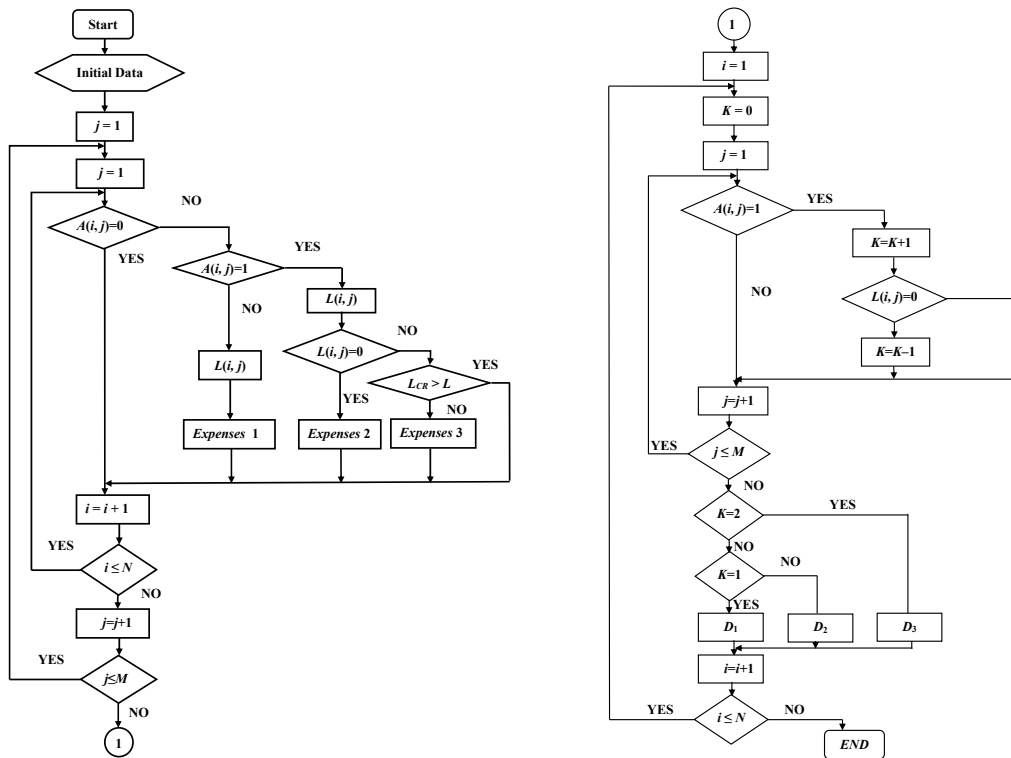

Fig. 4. The proposed and developed optimization algorithm of the power supply system

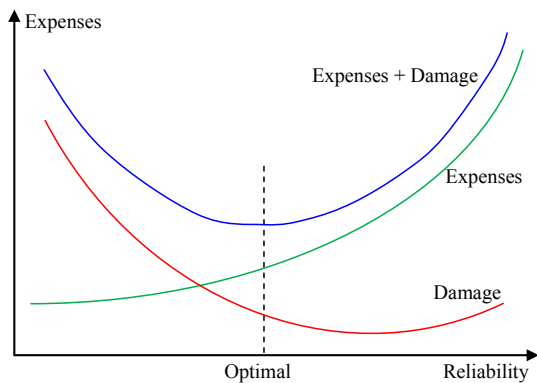

Fig. 5. Expenditure curves according to reliability [11]

Then the proper functioning of the power supply system results from the proper functioning of the various

elements that compose it. In other words, the overall reliability requirement is reflected in the form of specific reliability requirements for each element.

These elements can be mounted in only two methods: in series or in parallel (or mixed). Three variants of the power supply system were considered for compressor stations:

- a) from two electric lines;
- b) from a single electric line and a turbogenerator (stand-alone power plant);
- c) from two turbogenerators.

Our case study is based on this third variant of the supply system, i.e. from two turbogenerators.

Figure 6 shows the calculation of the reliability parameters λ , τ of the power supply system of compressor stations from two turbogenerators.

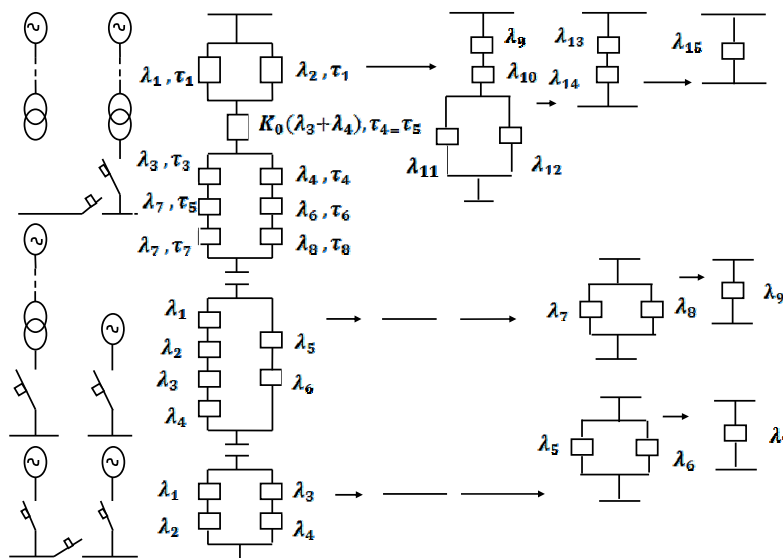

Fig. 6. Calculation of the reliability parameters λ , τ of the power supply system of compressor stations for the three variants

First variant of the power supply system – from two power lines.

First transformation.

$$\lambda_{1,2} = \lambda_1 \cdot \lambda_2 \cdot (\tau_1 + \tau_2) = \lambda_9; \quad (25)$$

$$\tau_{1,2} = \frac{\tau_1 \cdot \tau_2}{\tau_1 + \tau_2} = \tau_9, \quad (26)$$

where λ_1 and λ_2 are the failure rates of post 1 and post 2 respectively; τ_1 and τ_2 are the repair times of post 1 and post 2 respectively;

$$\lambda_{3,5} = \lambda_3 + \lambda_5 + \lambda_7 = \lambda_{11}; \quad (27)$$

$$\lambda_{4,6} = \lambda_4 + \lambda_6 + \lambda_8 = \lambda_{12}; \quad (28)$$

$$\tau_{3,5} = \frac{\lambda_3 \cdot \tau_3 + \lambda_5 \cdot \tau_5 + \lambda_7 \cdot \tau_7}{\lambda_3 + \lambda_5 + \lambda_7}; \quad (29)$$

$$\tau_{4,6} = \frac{\lambda_4 \cdot \tau_4 + \lambda_6 \cdot \tau_6 + \lambda_8 \cdot \tau_8}{\lambda_4 + \lambda_6 + \lambda_8}, \quad (30)$$

where λ_7 and λ_8 are the failure rates of the circuit breaker 0.4 kV; λ_3 and λ_4 are the failure rates of lines L₁ and L₂; λ_5 and λ_6 are the failure rates of transformers 1 and 2; τ_3 and τ_4 are the repair times of lines L₁ and L₂; τ_5 and τ_6 are the repair times of transformers 1 and 2.

Second transformation.

$$\lambda_{eq1} = \lambda_{1,2} + K_0(\lambda_3 + \lambda_4) = \lambda_{13}; \quad (31)$$

$$\tau_{eq1} = \frac{\lambda_{1,2} \cdot \tau_{1,2} + K_0(\lambda_3 + \lambda_4) \cdot \tau_3}{\lambda_{1,2} + K_0 \cdot (\lambda_3 + \lambda_4)} = \tau_{13}; \quad (32)$$

$$\lambda_{eq2} = \lambda_{3,5} \cdot \lambda_{4,6} (\tau_{3,5} + \tau_{4,6}) = \lambda_{14}; \quad (33)$$

$$\tau_{eq2} = \frac{\tau_{3,5} \cdot \tau_{4,6}}{\tau_{3,5} + \tau_{4,6}} = \tau_{14}, \quad (34)$$

where K_0 is the coefficient of the climatic conditions influence; $K_0(\lambda_3 + \lambda_4)$ is the failure rate of the lines L₁ and L₂ simultaneously; τ_0 is the repair time of the two lines $\tau_0 = \tau_3 = \tau_4$.

Third transformation.

$$\lambda_{15} = \lambda_{13} + \lambda_{14}; \quad (35)$$

$$\tau_{15} = \frac{\lambda_{13} \cdot \tau_{13} + \lambda_{14} \cdot \tau_{14}}{\lambda_{13} + \lambda_{14}}. \quad (36)$$

Finally, the expression of the probability of failure of the power supply system from two electric lines can be represented as follows:

$$Q = \tau_{15} \cdot \left(1 - e^{-\lambda_{15}}\right) / 8760. \quad (37)$$

Second variant of the power supply system – from a single electric line and a turbogenerator.

First transformation.

$$\lambda_7 = \lambda_1 + \lambda_2 + \lambda_3 + \lambda_4; \quad \lambda_8 = \lambda_5 + \lambda_6 \quad (38)$$

$$\tau_7 = \frac{\lambda_1 \cdot \tau_1 + \lambda_2 \cdot \tau_2 + \lambda_3 \cdot \tau_3 + \lambda_4 \cdot \tau_4}{\lambda_1 + \lambda_2 + \lambda_3 + \lambda_4}; \quad (39)$$

$$\tau_8 = \frac{\lambda_5 \cdot \tau_5 + \lambda_6 \cdot \tau_6}{\lambda_5 + \lambda_6}, \quad (40)$$

where $\lambda_1 - \lambda_4$ are the failure rate of the electrical post, overhead line, transformer and the circuit breaker 0.4 kV respectively; $\tau_1 - \tau_4$ are the failure rate of the turbogenerator and the circuit breaker 0.4 kV respectively; λ_5 and λ_6 are the failure rate of turbogenerator and the circuit breaker 0.4 kV respectively; τ_5 and τ_6 are the repair times of the turbogenerator and the circuit breaker 0.4 kV respectively.

Second transformation.

$$\lambda_7 = \lambda_7 \cdot \lambda_8 (\tau_7 + \tau_8); \quad \tau_9 = \frac{\tau_7 \cdot \tau_8}{\tau_7 + \tau_8}. \quad (41)$$

The expression of the probability of failure of the power supply system is:

$$Q = \tau_9 \cdot (1 - e^{-\lambda_9}) / 8760. \quad (42)$$

Third variant of the power supply system – from two turbogenerators.

First transformation.

$$\lambda_5 = \lambda_1 + \lambda_2; \quad \lambda_6 = \lambda_3 + \lambda_4, \quad (43)$$

$$\tau_5 = \frac{\lambda_1 \cdot \tau_1 + \lambda_2 \cdot \tau_2}{\lambda_1 + \lambda_2}; \quad \tau_6 = \frac{\lambda_3 \cdot \tau_3 + \lambda_4 \cdot \tau_4}{\lambda_3 + \lambda_4}, \quad (44)$$

where λ_1 , λ_3 and λ_2 , λ_4 are the failure rate turbogenerator and the circuit breaker 0.4 kV respectively; τ_1 , τ_3 and τ_2 , τ_4 are the repair times of the turbogenerator and the circuit breaker 0.4 kV respectively.

Second transformation.

$$\lambda_7 = \lambda_5 \cdot \lambda_6 (\tau_5 + \tau_6); \quad \tau_7 = \frac{\tau_5 \cdot \tau_6}{\tau_5 + \tau_6}. \quad (45)$$

The expression of the probability of failure of the power supply system is:

$$Q = \tau_7 \cdot \left(1 - e^{-\lambda_7}\right) / 8760. \quad (46)$$

The general formula of damage caused by accidental power system failures for all three variants is:

$$D = 1.08 \cdot P_M \cdot 8760 \cdot Q \cdot \varepsilon \cdot \beta_m \cdot \beta_q \cdot C_0, \text{ DA}. \quad (47)$$

The Table 2 illustrates the reliability parameters of electrical equipment for different voltages.

Table 2
Reliability parameters of electrical equipment for different voltages

Electrical equipment	Failure rate λ , 1/year	MTBF, h	Repair time τ , h	MTTR, h	
Airline (100 km)	30 kV	2.2	0.454	5.6	0.178
	60 kV	2.0	0.5	5.6	0.178
	220 kV	1.4	0.714	6.5	0.153
Circuit breaker (6–10) kV	30 kV	0.005	200	10	0.1
	60 kV	0.005	200	10	0.1
	60 kV	0.005	200	10	0.1
	220 kV	0.02	50	24	0.041
Transformer (6–10) kV	30 kV	0.023	43.478	70	0.014
	30 kV	0.018	5.555	90	0.011
	60 kV	0.02	50	100	0.01
	220 kV	0.02	50	100	0.01
Turbogenerator 0.4 kV	5.80	0.172	70	0.014	

Graphical presentation of the calculation. The operating procedure for the calculation of the optimization algorithm of the power supply systems of the five compressor stations has wide limits by combining the different variants of the power supply system that may exist.

In our case, as an explanation, we are limited to three variants of the electrical supply system for two compression

stations, knowing that each compression station has two independent power stations (turbogenerators).

Figure 7 clearly, shows the graphic presentation of the calculation of the three variants of the electrical supply system for two compression stations.

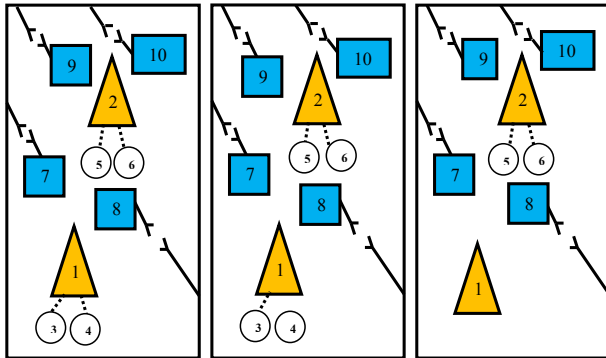

Fig. 7. Graphic presentation of the calculation

First variant. By keeping the local power supply system from two autonomous power plants of each compressor station, the calculation gave us the total expenses C_{t1} .

Second variant. By replacing a stand-alone power plant with a electric line, that is to say, power is supplied from a substation and a stand-alone power plant, the total expenditure which was found to be C_{t2} is lower than the total expenditure C_{t1} ($C_{t1} > C_{t2}$).

Third variant. The power supply to a compressor station is provided by two independent electric lines, which allowed us to obtain the total expenses as C_{t3} below the total expenses C_{t2} ($C_{t1} > C_{t2} > C_{t3}$), the variant of the most optimal power supply system with the minimum total expenditure ($C_t \rightarrow \min$).

Calculation procedure on the computer.

Initial data.

A. Expenditure calculation.

1. see if $A(i, j) = 1$
2. calculation of $L(i, j)$
3. see if $L(i, j) \leq L_{cr}$
4. calculation of installation and operating expenditure for $L(i, j)$ (post $j \rightarrow CS_i$)
5. if $L(i, j) = 0$
6. calculation of operating and installation expenses for turbogenerators ($TA_j \rightarrow CS_i$).
7. if $A(i, j) = -1$
8. calculation of operating expenditure for the existing line (post $i \rightarrow$ post j)
9. calculation: $C_p(i, j) = \sum_{i=1}^n \sum_{j=1}^m C_p(i, j)$. (48)

B. Damage calculation.

1. if $A(i, j) = 1$
2. see if $K = 2$
3. calculation of damages for the two-line PSS.
4. see if $K = 1$
5. calculation of damage for the single-line PSS and a turbogenerator.
6. see if $K = 0$
7. calculation of the damage for the PSS with two turbogenerators

$$8. \text{ calculation: } D(i) = \sum_{i=1}^5 D(i), \quad (49)$$

9. sum total expenditure:

$$D(i, j) = \sum_{i=1}^n \sum_{j=1}^m C_p(i, j) + \sum_{i=1}^5 D(i), \quad (50)$$

10. calculation of total expenditure for each variant according to the matrix (mathematical model of PSS chosen for the five (5) CS).

11. take the most optimal variant, the total expenditure of which will be minimal.

Conclusion.

This paper proposed a recent optimization technique based on the proposal of an algorithm combining two technical and economic aspects to help the operator to minimize the failures of the power supply systems directly influencing the reduction of the uptime of the turbocompressors (restart fuel and oil losses, etc.). In this study, we calculated the reliability parameters of three variants of the power supply system that were considered for compressor stations, from two electric lines, a single electric line, and a turbogenerator. Then, we calculated the damage. A graphical presentation by graph theory of this developed model is adequate.

From the calculation results, it can be concluded that currently taking into account the economic criterion and the initial data retained, the supply of electrical energy to the gas compression station «C» located at CHAIBA, is carried out from two autonomous sources, but from the point of view of reliability (technical criteria) or clearly sees that the power supply of the above-mentioned station, from two independent external lines is imposed.

From the results of the research, it can be said that the presented algorithm, developed in the FORTRAN programming language, greatly facilitates the calculation of the damage to the power system of any compressor station.

In the future, with the construction of new distribution stations near the gas compressor stations and the actual data, it can be seen that the variant of the supply system from two independent external lines is the most optimal. This allowed us to calculate the preventive power supply of two independent substations and impose the appropriate maintenance policies.

Conflict of interest. The authors declare that they have no conflicts of interest.

REFERENCES

1. Tikhomirova E. Provision of electric power to CS of TGP, using renewable energy sources (on the example of wind turbines). Master of science thesis EGI, KTH, The Royal Institute of Technology, School of Industrial Engineering and Management, Stockholm, 2012, 86 p. Available at: <https://www.diva-portal.org/smash/get/diva2:617506/FULLTEXT01.pdf> (accessed 20.10.2020).
2. Ríos-Mercado R.Z., Borraz-Sánchez C. Optimization problems in natural gas transportation systems: A state-of-the-art review. *Applied Energy*, Jun. 2015, vol. 147, pp. 536-555. doi: <https://doi.org/10.1016/j.apenergy.2015.03.017>.
3. Luongo C., Gilmour B., Schroeder D. Optimization in natural gas transmission networks: A tool to improve operational efficiency. *Proceedings of the Third SIAM conference on optimization*, Boston, USA, 1989.
4. Turysheva A.V., Baburin S.V. Justification of power supply system's structure of oil and gas facilities using backup energy

sources with associated petroleum gas as the energy carrier. *International Journal of Applied Engineering Research*, 2016, vol. 11, no. 1, pp 749-755. Available at: <https://www.researchgate.net> (accessed 20.10.2020).

5. Kurz R., Lubomirsky M., Brun K. Gas Compressor Station Economic Optimization. *International Journal of Rotating Machinery*, vol. 2012, article number 715017, 9 p. doi: <https://doi.org/10.1155/2012/715017>.

6. Bansal R.C. Optimization methods for electric power systems: An overview. *International Journal of Emerging Electric Power Systems*, Jan. 2005, vol. 2, iss. 1, article number 1021. doi: <https://doi.org/10.2202/1553-779x.1021>.

7. Baburin S.V., Kovalchuk M.S. Analysis of power supply systems reliability for gas pumping compressor stations. *2018 IEEE Conference of Russian Young Researchers in Electrical and Electronic Engineering (EIConRus)*, Moscow and St. Petersburg, Russia, 2018, pp. 566-569. doi: <https://doi.org/10.1109/eiconrus.2018.8317161>.

8. Massim Y., Zebalah A., Benguediab M., Ghouraf A., Meziane R. Reliability evaluation of electrical power systems including multi-state considerations. *Electrical Engineering*, Aug. 2004, vol. 88, no. 2, pp. 109-116, doi: <https://doi.org/10.1007/s00202-004-0262-2>.

9. *Prévision de consommation d'électricité à moyen terme*. Direction de planification SONELGAZ, Juin 1984. (Fra).

10. *Military Handbook 338. Electronic Reliability Design Handbook*, October 1998. Available at http://everyspec.com/MIL-HDBK/MIL-HDBK-0300-0499/MIL-HDBK-338B_15041 (accessed 20.10.2020).

11. Villemeur A. *Sûreté de fonctionnement des systèmes industriels : fiabilité, facteurs humains, informatisation*. Paris: Eyrolles, 1988. (Fra).

12. Pages A. *Fiabilité des systèmes d'alimentation électrique*. Paris, 1980. (Fra).

Received 20.12.2020

Accepted 25.01.2020

Published 05.04.2021

Nedjem-Eddine Benchouia¹, Ph.D., HDR,
Mohamed Saaidia², Ph.D.,

¹ Department of Mechanical Engineering,
Mohamed-Cherif Messaadia University,
Souk Ahras mailbox 1553, Souk-Ahras, 41000, Algeria,
e-mail: n.benchouia@univ-soukahras.dz

² Department of Electrical Engineering,
Mohamed-Cherif Messaadia University,
Souk Ahras mailbox 1553, Souk-Ahras, 41000, Algeria,
e-mail: mohamed.saaidia@cu-soukahras.dz

Appendix 1 – Proposed program in FORTRAN code

```
! PSS SC Program
Dimension X(9), Y(9), W(11), V(11), pril(11,9), uam(11,9),
+upe(11,9), uen(11,9), d1(11,9), d(2), prixg(11,9), td30(9),
+tao30(9), tdl30(11,9), tdc30(11,9), tao30(11,9), t30(2),
+s30(2), e30(2), d30(2), X30(2), h30(2), C30(2),
+prob(2)
Integer a(11,9)
Real l(11,9), lcr1
Data td30/0.,0.,0.,0.,0.5,0.5,0.5,0.5,0.5/
+tao30/0.,0.,0.,0.,0.02,0.02,0.02,0.02,0.02/
Data X/55.,55.,89.,89.,32.5,115.,118.,27.5,62.5/
+Y/62.5,62.5,97.5,97.5,82.5,82.,107.,161.5,152./
Data W/55.,89.,55.,55.,89.,89.,32.5,115.,118.,97.5,62.5/
+V/62.5,97.5,62.5,62.5,97.5,97.5,82.5,82.,107.,161.5,152/
Data Pril1/20./,Pritr1/100./,Alp1/0.02/,ALP2/0.06/,
+ALP3/0.07/,prig/3500./,r01/0.77/,R02/0.64/,taom/5948./,
+delp/3.1/,delpc/18./,ch/0.7/,betm/0.97/,betq/0.94/,
+tdtr1/0.02/,tddis/0.002/,tdg/5.8/,tao11/5.6/,
```

```
+taodis/1.75/,taog/70./,pm/2214.24/,epsi/1./,u1/30./,
+s/1232.5/,u2/60./,c0/0.00055/,taotr1/90./,tdl1/2.2/
Data a/1,0,-1,0,0,0,0,0,0,0,0,0,0,-1,0,0,0,0,0,0,0,0,
+0,0,-1,0,0,0,0,0,0,0,0,0,0,-1,0,0,0,0,0,1,0,0,0,0,
+0,-1,0,0,0,0,-1,0,0,0,0,0,-1,0,0,0,0,0,0,0,0,-1,
+-1,0,0,0,0,0,0,0,0,0,-1,-1,0,1,0,0,0,0,0,0,0,0,
+-1/
Data lcr1/50./
Open (unit=15,file='bou.d',status='unknown')
J=1
6 do 4 i =1,2
If(a(i,j).eq.0) goto 4
l(i,j) = sqrt((x(j)-w(i))**2+(y(j)-v(i))**2)
if(l(i,j).eq.0.) goto 15
if(l(i,j).gt.lcr1) goto 4
pril(i,j)=pril1*(i,j)+(pritr1)
uam(i,j)=(alp1*(pril1*(i,j)))+(alp2*(pritr1))
uen(i,j)=0.2*uam(i,j)
upe(i,j)=(((s**2/u1**2)*r01*(i,j)*taom)+
+((delp*8760)+(delpc*ch**2*taom))*c0
d1(i,j)=0.12*pril(i,j)+uam(i,j)+uen(i,j)+upe(i,j)
write(15,12),i,j,d1(i,j)
goto 4
15 prixg(i,j)=prig
Uam(i,j) = alp3*prixg(i,j)
Uen(i,j)=0.2*uam(i,j)
d1(i,j)=0.12*prixg(i,j)+uam(i,j)+uen(i,j)
write(15,12),i,j,d1(i,j)
12 format(3X,»d1(«i2,»,»,i2,») = «e11.4)
4 continue
J=j+1
If(j.le.9) goto 6
J=1
3 do 7 i=3,11
If(a(i,j).eq.0) goto 7
L(i,j)=sqrt((x(j)-w(i))**2+(y(j)-v(i))**2)
D1(I,J)=((s**2/60**2)*r02*(i,j)*taom)*c0
Write(15,12),I,j,d1(I,j)
13 format(3X,»d1(«i2,»,»,i2,») = «e11.4)
7 continue
J=j+1
If(j.le.9) goto 3
I=1
80 k=0
Do 10 j=1,9
If(a(I,j).ne.1) goto 10
K=k+1
If(L(I,j).ne.0) goto 10
K=K-1
10 continue
If(k.eq.2.) goto 14
If(k.eq.1) goto 16
If(k.eq.0) goto 18
14 do 20 j=1,9
If(a(I,j).ne.1) goto 20
If(l(I,j).gt.lcr1) goto 20
If(l(I,j).eq.0) goto 20
tdl30(I,j)=tdl1*(I,j)/100
tdc30(I,j)=tdl30(I,j)+tdtr1+tddis
tao30(I,j)=((tdl30(I,j)*tao11)+(tdtr1*taotr1)+
+(tddis*taodis))/tdc30(I,J)
20 continue
T30(i)=0
S30(i)=0
E30(i)=1
D30(i)=1
X30(i)=1
H30(i)=1
C30(i)=0
```

```

Do 30 J=1,9
If(a(I,j).ne.1) goto 30
If(l(I,j).gt.lcr1) goto 30
If(l(I,j).eq.0) goto 30
t30(i)=t30(i)+tdl30(I,j)
e30(i)=e30(i)*td30(j)
s30(i)=s30(i)+tao30(j)
d30(i)=d30(i)*tao30(j)
c30(i)=c30(i)+taoc30(I,j)
h30(i)=h30(i)*taoc30(I,j)
x30(i)=x30(i)*tdc30(I,j)
30 continue
Td9 =e30(i)*s30(i)/8760
Td34=0.2*t30(i)
Td12=td9+td34
Tao9=d30(i)/s30(i)
Tao12=((td9*tao9)+(td34*tao34))/td12
Td13=x30(i)*c30(i)/8760
Tao13=h30(i)/c30(i)
Td14=td12+td13
Tao14=((td12*tao12)+(td13*tao13))/td14
Prob(i)=(tao14*(1-exp(-td14)))/8760
D(i)=1.08*pm*8760*prob(i)*epsi*betm*betq*c0
Write(15,26) I,d(i)
26 format(3x',d('i1,')=',e11.4)
Goto 100
16 do 60 j=1,9
If(a(I,j).ne.1) goto 60
If(l(I,j).gt.lcr1) goto 60
If(l(I,j).eq.0) goto 60
Tdl30(I,j)=tdl1*(I,j)/100
Tdc30(I,j)=tdl30(I,j)+td30(j)+tdr1+tddis
Taoc30(I,j)=((tdl30(I,j)*tao11)+(td30(j)*tao30(j))+
+ (tdr1*taotr1)+(tddis*taodis))/tdc30(I,j)
60 continue
Do 107 j=1,9
If(a(I,j).ne.1) goto 107
If(l(I,j).gt.lcr1) goto 107
If(l(I,j).eq.0) goto 107

```

```

Td8=tdg+tddis
Tao8=((tdg*taog)+(tddis*taodis))/td8
Td9=(tdc30(I,j)*td8)*(taoc30(I,j)+tao8)/8760
Tao9=taoc30(I,j)*tao8/(taoc30(I,j)+tao8)
107 continue
Prob(i)=(tao9*(1-exp(-td9)))/8760
D(i)=1.08*pm*8760*prob(i)*epsi*betm*betq*c0
Write(15,26)I,d(i)
Goto 100
18 td5=tdg+tddis
Tao5=(tdg*taog+tddis*taddis)/td5
Td7=(td5**2)*(tao5+tao5)/8760
Tao7=tao5/2
Prob(i)=(tao7*(1-exp(-td7)))/8760
D(i)=1.08*pm*8760*prob(i)*epsi*betm*betq*c0
Write(15,26) I,d(i)
100 i=i+1
If(i.le.2) goto 80
Close (unit =15)
Stop
End
Result
d1( 1, 1)= 0.7140E+03
d1( 1, 5)= 0.1281E+06
d1( 2, 6)= 0.1288E+06
d1( 3, 1)= 0.0000E+00
d1( 4, 2)= 0.0000E+00
d1( 5, 3)= 0.0000E+00
d1( 6, 4)= 0.0000E+00
d1( 7, 5)= 0.0000E+00
d1( 8, 6)= 0.0000E+00
d1( 8, 7)= 0.2224E+05
d1( 9, 7)= 0.0000E+00
d1(10, 8)= 0.6184E+05
d1(11, 8)= 0.3204E+05
d1(11, 9)= 0.0000E+00
.d(1)= 0.2011E+00
.d(2)= 0.2011E+00

```

How to cite this article:

Benbouia N., Saaidia M. Optimization and reliability of the power supply systems of a compressor station. *Electrical Engineering & Electromechanics*, 2021, no. 2, pp. 54-63. doi: 10.20998/2074-272X.2021.2.08.