

K.I. Snitkov, Y.V. Shabatura

A METHOD OF REDUCING THE ERROR IN DETERMINING THE ANGULAR DISPLACEMENTS WHEN USING INDUCTIVE SENSORS

Goal. Representation of a special mathematical software for determining the angular displacements of the rotor of the induction angle sensor – resolver (rotating transformer) for applications in which the speed of the sensor's rotor is close to zero. As well as performing its experimental verification. Methodology. The presented method is based on the determination of the phase shift angle of the output signals of the induction sensor, which is determined by comparing the obtained arrangements of signal values with a circular discrete convolution in order to achieve the most precise approximation of the obtained signal values to cosine and sine. The conversion of orthogonal components to an angle is based on the use of a digital phase detector which is use of a software comparator and inverse trigonometric functions. Results. Based on the obtained results of mathematical modeling and experimental research, the characteristic dependencies of the angle of rotation of the rotor of the induction sensor relative to its stator, the nature of which is linear, were obtained. In addition, the estimation of measurement errors of angular displacements is carried out that occur when defining such angles by the method offered. The obtained results of the computer simulation taking into account the high signal noise, as well as the results of experimental investigations, confirm the high precision of this method and the fact that it can be used in systems where high positioning accuracy is required and the speed of the sensor shaft is close to zero. Originality. This article introduces, for the first time, special mathematical software for a new method of determining the angular displacements of the rotor of an induction sensor, which is based on the determination of the orthogonal components of the signal in combination with the use of a circular discrete convolution in the determination of the phase shift angle of the induction sensor signals. Practical meaning. The proposed method does not require the use of demodulators, counters and quadrant tables associated with conventional methods for determining the phase shift of signals. The presented method can be used to measure the full range of $0-2\pi$ angular displacements in real time, is simple and can be easily implemented using digital electronic circuitry. References 9, tables 3, figures 16.

Key words: angular displacements, mathematical method, induction sensor, rotating transformer, circular discrete convolution, orthogonal components, precision, phase shift.

У роботі виконано дослідження нового методу зменшення похибки визначення кутових переміщень за допомогою індукційного давача, його математичне забезпечення та експериментальна перевірка. Представлений метод базується на вимірюванні кута зсуву фаз сигналів давача, визначення якого здійснюється за допомогою співставлення оцифрованих значень сигналів давача із круговою дискретною згорткою та подальшим визначенням їх ортогональних складових. На основі значень отриманих ортогональних складових здійснюється визначення кута за допомогою цифрового детектору фази, в основі роботи якого лежить застосування програмного компаратору та обернених тригонометричних функцій. Запропонований метод не вимагає використання демодуляторів, лічильника та таблиць квадрантів, які асоціюються із традиційними методами визначення кута зсуву фаз сигналів. Представлений метод може бути використаний для вимірювання кутів у діапазоні $0-2\pi$, є простим, і може бути легко реалізований за допомогою цифрових засобів. Бібл. 9, табл. 3, рис. 16.

Ключові слова: кутові переміщення, математичний метод, індукційний давач, обертовий трансформатор, кругова дискретна згортка, ортогональні складові, прецизійність, зсув фази.

В работе выполнено исследование нового метода уменьшения погрешности определения угловых перемещений с помощью индукционного датчика, его математическое обеспечение и экспериментальная проверка. Представленный метод основан на измерении угла сдвига фаз сигналов датчика, определение которого осуществляется с помощью сопоставления оцифрованных значений сигналов датчика с круговой дискретной сверткой и последующим определением их ортогональных составляющих. На основе значений полученных ортогональных составляющих осуществляется определение угла с помощью цифрового детектора фазы, в основе работы которого лежит применение программного компаратора и обратных тригонометрических функций. Предложенный метод не требует использования демодуляторов, счетчика и таблиц квадрантов, которые ассоциируются с традиционными методами определения угла сдвига фаз сигналов. Представленный метод может быть использован для измерения углов в диапазоне $0-2\pi$, является простым, и может быть легко реализован с помощью цифровых средств. Библ. 9, табл. 3, рис. 16.

Ключевые слова: угловые перемещения, математический метод, индукционный датчик, вращающийся трансформатор, круговая дискретная свертка, ортогональные составляющие, точность, сдвиг фазы.

Introduction. Today, in many fields of science and technology as devices that provide information about the current state of the actuators, angle measuring systems are widely used. In most cases, especially for devices and mechanisms that work in extreme conditions, electromechanical sensors (angle sensors) are used, the work of which is aimed at converting angular displacements into an information signal.

As is known from [1] to determine the angular displacements, there are a large number of types of sensors, such as: optical encoder, gyroscopic sensors,

magnetic encoder, and induction sensors. However, the use of the above types of sensors in angular measurement systems should be used taking into account the purpose of such systems, environmental conditions and requirements for their accuracy. There is no doubt that today optical encoders have become widely used in angular measuring and positioning systems. However, despite their widespread use, positioning systems continue to operate today, using induction electromechanical transducers as part of the control system, both in the field of armaments

© K.I. Snitkov, Y.V. Shabatura

and military equipment, and in industries. The use of induction electromechanical transducers in the above fields is explained by their ability to operate in difficult operating conditions and unpretentiousness to external conditions [2]. However, along with the positive properties, they also have disadvantages – induction mechanical transducers do not provide high enough accuracy to identify angular displacements. In particular, in tracking systems, positioning systems and automated weapons guidance systems, where such sensors are the main sensors of angular movements. The use of the aforementioned sensors such as optical encoder, electron gyroscope, with the appropriate bit rate, would allow the identification of angular displacements with higher accuracy, the requirements for which, to date, reach tens of angular seconds. However, their use does not meet the above requirements for the operating conditions of such systems. In addition, in the case of modernization of angle measuring systems, which operate on the basis of the use of an induction sensor, by replacing it with modern digital encoder will involve significant financial costs, as well as design changes in the system.

Thus, given the above, there is a need to increase the accuracy of determining the angular displacements using an induction sensor, which is used in existing and advanced angle measuring systems based on the use of special mathematical processing of the information signal of such a sensor.

Analysis of publications. Today, many publications are known, which consider both hardware and software methods and means of determining the angle of rotation of the rotor of the induction sensor, most of which are considered in [3]. The analysis of these publications provides an opportunity to gain knowledge about the existing methods of determining the angular displacements of the induction sensor, as well as to get acquainted with promising areas of future research.

In particular, the use of analog hardware (so-called signal filters), which operate on the basis of the use of R , C elements really do reduce the error of identification of the angle, but with insufficient accuracy. Moreover, its further increase is impossible due to the influence of destabilizing factors, such as temperature, time, frequency, which affect both the parameters of R , C elements and the parameters of the induction angle sensor [4]. Also, digital tools offered by leading electronics manufacturers (e.g. Texas Instruments, Freescale Semiconductor, Analog Devices) have become widespread, as ready-made solutions for processing information signals of the induction converter based on the implementation of simple calculations using modern electronic components in combination with microcontroller technology [5]. Also, in [6], the latest software and hardware method for identifying the angle of rotation of the rotor of the induction sensor, which is based on the use of phase autotuning frequency is proposed. Using the proposed scheme of this software and hardware method, there is no need to demodulate the signal, use a table of quadrants, pulse counters and digital-to-analog converters. However, the error in determining the angles of rotation of the rotor of the sensor when using this method is 0.3 % over the full

range of values 0-360°. Also, such a hardware-software method is based on the proposed scheme, the implementation of which is carried out using simple electronic elements, in particular, resistors, and therefore the ambient temperature factor will affect the accuracy of the identification results.

In [7, 8] methods of converting sensor signals into an angular position based on the application of mathematical calculations using a polynomial of the 3rd order [7], and generating auxiliary sinusoidal signals [8], for the implementation of which semiconductor components and microcontrollers are used are presented. As a result of application of such methods high accuracy of definition of angular positions at high frequency of rotation of a shaft is reached. However, in the above methods, it is proposed to demodulate the sine and cosine signals to determine the angle of rotation, and therefore it is assumed that the sensor shaft must rotate at a given speed required to modulate these signals. Based on the above, the use of such methods is impossible in systems such as stabilization, positioning, or systems using gearless actuators, where the speed of rotation of the sensor shaft is close to zero.

Thus, **the goal of the work** is the development of special mathematical software for determining the angular displacements of the rotor of the induction sensor based on the determination of orthogonal components from the digital values of the sensor signals using circular discrete convolution. Also in the paper the experimental check of the developed special mathematical tool for induction angle measuring sensors in which the speed of rotation of a rotor is close to zero is carried out.

In this work, an induction sensor – resolver (rotating transformer) is used as an angle sensor. The design of such sensors is typical and consists of two windings placed on the stator in the same magnetic system, but their geometric axes are perpendicular to each other. Similarly, the rotor windings are in the same magnetic system and are mutually perpendicular to each other. A typical way to provide excitation of a rotating transformer is to connect one of its stator windings to the mains, and the other winding is short-circuited or connected to a potentiometer, which is implemented in the method considered in [7].

However, **the essence** of the implementation of the **method** proposed by the authors of this work is not to measure the amplitudes of the signal with its subsequent demodulation, but to determine the phase shift between input and output signals, which can be done by connecting both induction windings of the sensor to the power supply of sinusoidal voltages, as shown of (Fig. 1).

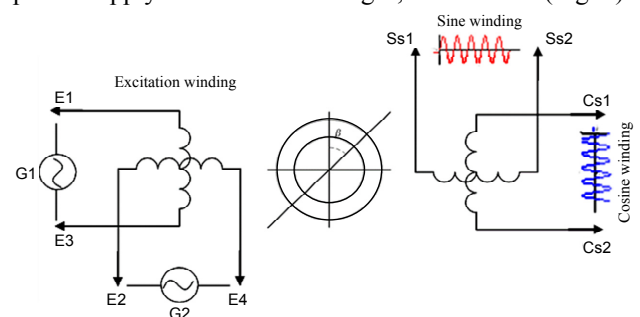

Fig. 1. Configuration of induction sensor windings

Figure 1 shows a diagram of the specified configuration of the windings of the induction sensor – a rotating transformer to determine the phase shift of the output signal depending on the angle of rotation of the rotor of this sensor. The excitation voltage G1, G2, which is equal in amplitude and frequency, but shifted relative to each other by 90°, is applied to the terminals of the excitation winding E1-E3 and E2-E4, respectively, which can be described by the following expressions:

$$G1 = U_{fs} = A \cdot \sin(\omega t), \quad (1)$$

$$G2 = U_{fc} = A \cdot \cos(\omega t), \quad (2)$$

where A is the amplitude of the supply voltage of the sensor, ω is the angular frequency of the excitation signal, t is the time.

Due to the receipt of symmetrical current supply, in the air gap of the magnetic system of the induction sensor there is a rotating magnetic field, the vector of which has a constant value and rotates uniformly with the supply frequency. Then the signals generated on the terminals Ss1-Ss2 of the winding «sine winding» and on the terminals Cs1-Cs2 of the winding «cosine winding» take the form of a sinusoidal voltage of constant frequency, which are shifted in phase relative to the excitation voltage of the sensor, and the phase shift will be determined by the rotation angle of the induction sensor rotor, because the rotation of the magnetic field vector is carried out at a constant speed, so the maxima of the output signals will correspond to the time of passage of the magnetic field vector through the direction of the axis of the longitudinal winding of the induction sensor rotor. The description of the signals on the terminals Ss1-Ss2 of the winding «sine winding» and on the terminals Cs1-Cs2 of the winding «cosine winding» can be made by the following expressions:

$$U_{ss} = k \cdot A \cdot \sin(\omega t + \beta), \quad (3)$$

$$U_{cs} = k \cdot A \cdot \cos(\omega t + \beta), \quad (4)$$

where U_{ss} is the value of the signal at the terminals Ss1-Ss2 of the winding «sine winding», U_{cs} is the value of the signal at the terminals Cs1-Cs2 of the winding «cosine winding», k is the transformation factor, β is the angle of rotation of the rotor relative to the stator (in other words, β is the angle phase shift of the signal winding relative to the excitation winding).

Determination of the rotation angle of the rotor of the induction sensor relative to the stator is based on the method of determining orthogonal components from arrays of values that contain information about the signals of the sensor using a circular discrete convolution, which can be implemented according to the proposed simplified block diagram (Fig. 2).

In Fig. 2 the following notations are accepted: U_{fs} , U_{fc} – analog values of signals coming from the excitation winding and described by expressions (1) and (2); U_{ss} , U_{sc} – analog values of signal windings (3), (4); ADC (analog-to-digital converter) – m -channel analog-to-digital converter (ADC) with N_{ADC} bit rate and sampling frequency f_{adc} ; $U_{DC_{fc}}$, $U_{DC_{fs}}$, $U_{DC_{ss}}$, $U_{DC_{sc}}$ – digital values of signals of excitation windings and signals of signal windings after passing of the ADC block;

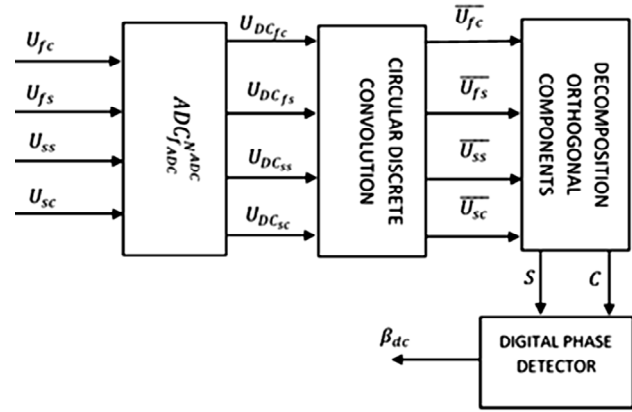

Fig. 2. Simplified block diagram of the proposed method for determining the angular displacements of the induction sensor

Circular Discrete Convolution – a block for forming a discrete convolution of the signal by multiplying the arrays, which are formed on the basis of the values of the signals obtained from the sensor windings with the values of the generated sinusoidal signals; $\overline{U_{fc}}$, $\overline{U_{fs}}$, $\overline{U_{ss}}$, $\overline{U_{sc}}$ – the results of the formation of arrays of values of the circular discrete convolution of the signal of the induction sensor in digital form; Decomposition Orthogonal Components – the block of release of orthogonal components, the result of which calculation is a pair of numbers S and C , which come to the block Digital Phase Detector – the block of digital phase detection. The result of the calculation in the Digital Phase Detector is the angle β_{dc} which is equal to the angle of the rotor position. Thus, as follows from the description of the operation of the above circuit, to implement the proposed method it is involved to use modern means for converting an analog signal into a digital code, as well as the use of microprocessor technology to perform calculations.

The operation of the proposed circuit is as follows: signals U_{fs} , U_{fc} , U_{ss} , U_{sc} which are described by expressions (1)-(4), come to the block $ADC_{f_{ADC}}^{N_{ADC}}$, the operation of which should convert the values of signals as functions of continuous variables into a function of discrete variables as a finite number samples of discrete values. Therefore, the values of the signals after the ADC conversion can be described by the following expressions:

$$U_{DC_{fc}} = A \cdot \frac{\text{trunc}(2^{N_{ADC}-1} \cdot \left(\frac{A + \text{rnd}(\delta) - \frac{\delta}{2}}{A} \right) \cdot \cos(\omega t_{si}))}{2^{N_{ADC}-1}}, \quad (5)$$

$$U_{DC_{fs}} = A \cdot \frac{\text{trunc}(2^{N_{ADC}-1} \cdot \left(\frac{A + \text{rnd}(\delta) - \frac{\delta}{2}}{A} \right) \cdot \sin(\omega t_{si}))}{2^{N_{ADC}-1}}, \quad (6)$$

$$U_{DC_{ss}} = A \cdot \frac{\text{trunc}(2^{N_{ADC}-1} \cdot \left(\frac{A + \text{rnd}(\delta) - \frac{\delta}{2}}{A} \right) \cdot \sin(\omega t_{si} + \beta))}{2^{N_{ADC}-1}}, \quad (7)$$

$$U_{DC_{sci}} = A \cdot \frac{\text{trunc}(2^{N_{ADC}-1} \cdot \left(\frac{A + \text{rnd}(\delta) - \frac{\delta}{2}}{A} \right) \cdot \cos(\omega t_{si} + \beta))}{2^{N_{ADC}-1}}, \quad (8)$$

where $U_{DC_{fci}}$, $U_{DC_{fsi}}$ are the digital values of the signals of the excitation winding of the induction sensor, $U_{DC_{ssi}}$, $U_{DC_{sci}}$ are the digital values of the signals of the sine winding and cosine winding, respectively; *trunc* function is the function of rounding a number to an integer value; *rnd* function is the software generator of random variables; δ is the value of random perturbations, which reaches 1 %, which is known from experimental studies [9], one of the results of such a study is shown in Fig. 3; $2^{N_{ADC}-1}$ is the ADC bit rate is reduced by one bit, which is used to determine the polarity of the function; t_{si} is the signal sampling period, which is determined by the formula:

$$t_{si} = i \cdot T_{adc}, \quad (9)$$

where i is the sequence number of the ADC sample, which takes values from 0 to N_s ; T_{adc} is the ADC reference period:

$$T_{adc} = \frac{1}{f_{adc}}, \quad (10)$$

$$N_s = \frac{f_{adc}}{f}, \quad (11)$$

where f_{adc} is the ADC sampling frequency; f is the excitation frequency of the induction sensor; N_s is the number of ADC samples.

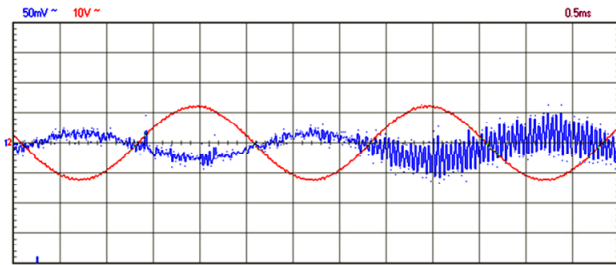

Fig. 3. Influence of random perturbations on the signal amplitude of the induction sensor

The obtained arrays of signal values $U_{DC_{fci}}$, $U_{DC_{fsi}}$, $U_{DC_{ssi}}$, $U_{DC_{sci}}$ are fed to the Circular Discrete Convolution block, in which the signal convolution is formed due to their multiplication with the generated sine function, thus digital signal filtering takes place. Based on this, formation of the signal convolution can be described by the following expressions:

$$\overline{U_{fc_i}} = \sum_{j=0}^{N_s} \left[U_{DC_{fci}} \cdot U_{\sin_i} \begin{cases} i-j, & \text{if } i-j \geq 0 \\ (i-j)+N_s, & \text{otherwise} \end{cases} \right] \cdot \frac{2}{N_s}, \quad (12)$$

$$\overline{U_{fs_i}} = \sum_{j=0}^{N_s} \left[U_{DC_{fsi}} \cdot U_{\sin_i} \begin{cases} i-j, & \text{if } i-j \geq 0 \\ (i-j)+N_s, & \text{otherwise} \end{cases} \right] \cdot \frac{2}{N_s}, \quad (13)$$

$$\overline{U_{ss_i}} = \sum_{j=0}^{N_s} \left[U_{DC_{ssi}} \cdot U_{\sin_i} \begin{cases} i-j, & \text{if } i-j \geq 0 \\ (i-j)+N_s, & \text{otherwise} \end{cases} \right] \cdot \frac{2}{N_s}, \quad (14)$$

$$\overline{U_{sc_i}} = \sum_{j=0}^{N_s} \left[U_{DC_{sci}} \cdot U_{\sin_i} \begin{cases} i-j, & \text{if } i-j \geq 0 \\ (i-j)+N_s, & \text{otherwise} \end{cases} \right] \cdot \frac{2}{N_s}, \quad (15)$$

where

$$U_{\sin_i} = \sin\left(2 \cdot \pi \cdot \frac{i}{N_s}\right). \quad (16)$$

The result of graphical modeling of expressions (12)-(13) is shown in Fig. 4, and expressions (14)-(15) – in Fig. 5.

After filtering through the digital filter of the Circular Discrete Convolution block, the digital signal arrays $\overline{U_{fc_i}}$, $\overline{U_{fs_i}}$, $\overline{U_{ss_i}}$, $\overline{U_{sc_i}}$ arrive at the Decomposition Orthogonal Components block, where they are decomposed into orthogonal components in the form of a pair of numbers S i C and which are essentially vector coordinates in the Cartesian coordinate system:

$$S = \sum_{i=0}^{N_s-1} \left(\overline{U_{ss_i}} \cdot \overline{U_{fs_i}} + \overline{U_{sc_i}} \cdot \overline{U_{fc_i}} \right), \quad (17)$$

$$C = \sum_{i=0}^{N_s-1} \left(\overline{U_{ss_i}} \cdot \overline{U_{fc_i}} - \overline{U_{sc_i}} \cdot \overline{U_{fs_i}} \right), \quad (18)$$

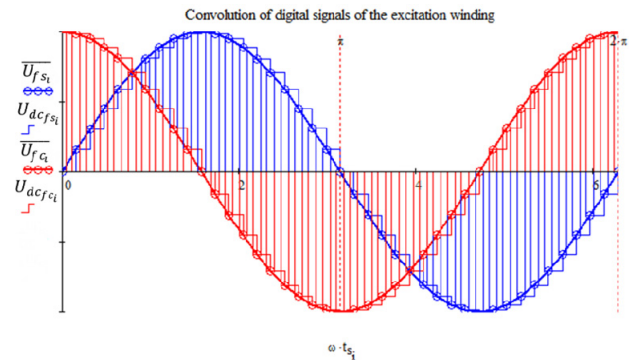

Fig. 4. Graphical representation of circular discrete convolution of digital signals of the excitation winding of the induction sensor

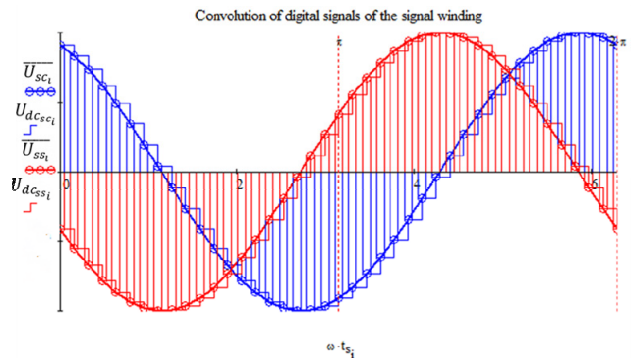

Fig. 5. Graphical representation of circular discrete convolution of digital signals of the signal windings of the induction sensor

To determine the phase shift of the signal, and hence the angle of rotation of the rotor relative to the stator of the sensor, the values of orthogonal components S and C go to the Digital Phase Detector, which converts the coordinates of the vector into the angular value of the rotor position in real time according to the algorithm shown in Fig. 6.

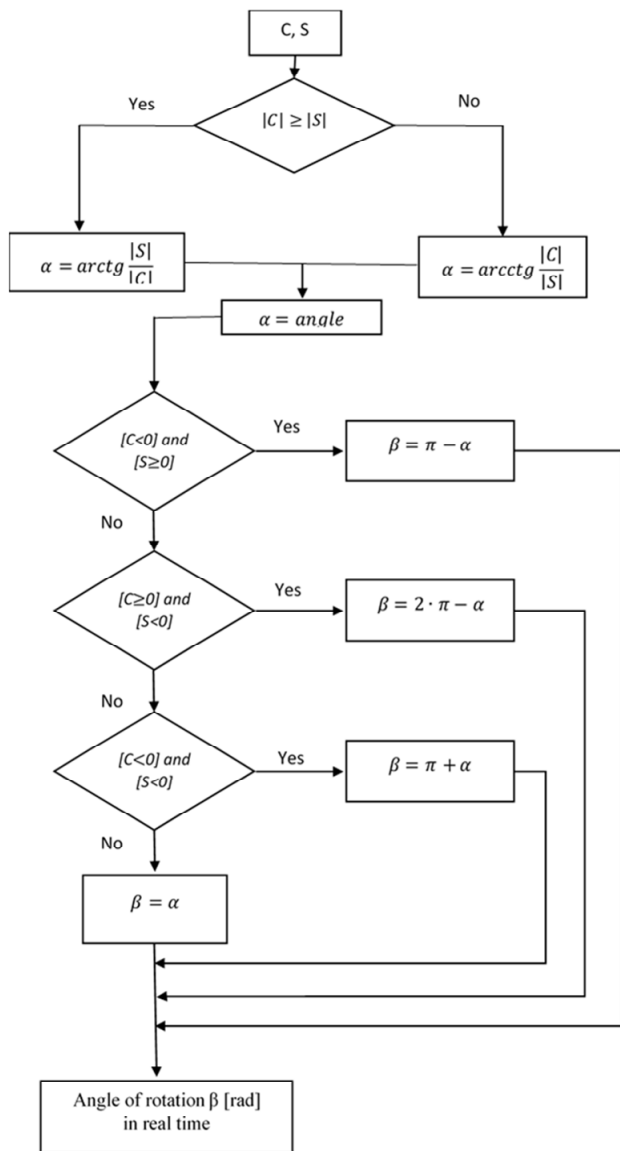

Fig. 6. Algorithm of the Digital Phase Detector block operation

On the basis of expressions (1)-(18) computer simulation was performed using the values of the parameters of real ADC and induction sensor, which are listed in Table 1.

Table 1

ADC and induction sensor parameters		
Parameter	Values	Units
ADC		
Bit rate	2^{16}	Bit
Frequency of samples	$10 \cdot 10^3$	Hz
Induction sensor		
Amplitude of excitation voltage	12	V
Frequency of excitation voltage	400	Hz

The results of this computer simulation are shown in Fig. 7, where φ is the value of the angles that are set, β_s is the value of the angles that are determined.

In addition, the constructed mathematical models allowed to obtain the dependencies of the errors in determining the angle (based on the method of determining orthogonal components using a circular discrete convolution) on the angle of rotation of the rotor of the induction sensor:

$$\delta = \varphi - \beta_s, \quad (19)$$

where δ is the error of determining the angle in absolute values (rad).

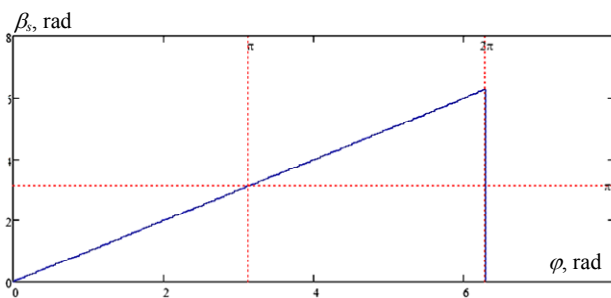

Fig. 7. Dependence of the determined angle β_s on the angle of rotation of the rotor of the induction sensor φ in the full range of angular displacements $0 - 2\pi$

The graphical result of modeling expression (19) is shown in Fig. 8.

Simulation of the error δ dependencies of the angle β_s determination on the angle of rotation of the rotor of the induction sensor φ allows to obtain the value of the root mean square error θ

$$\theta = \sqrt{\frac{1}{N-1} \sum_{i=0}^{N-1} (\delta_i^2)} = 9.73 \cdot 10^{-5} (\text{rad}), \quad (20)$$

where N is the number of defined angles, in the range from 0 to 2π , which in a computer experiment takes the value of 60,000.

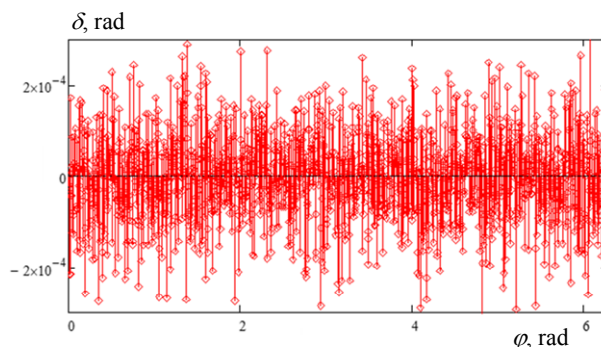

Fig. 8. Dependence of errors δ of the determination of the angle β_s on the angle of rotation of the rotor of the induction sensor φ

Experimental verification of the obtained results.

In order to confirm the results of theoretical modeling of the proposed method, an experimental study was conducted using laboratory equipment, the general view of which is shown in Fig. 9.

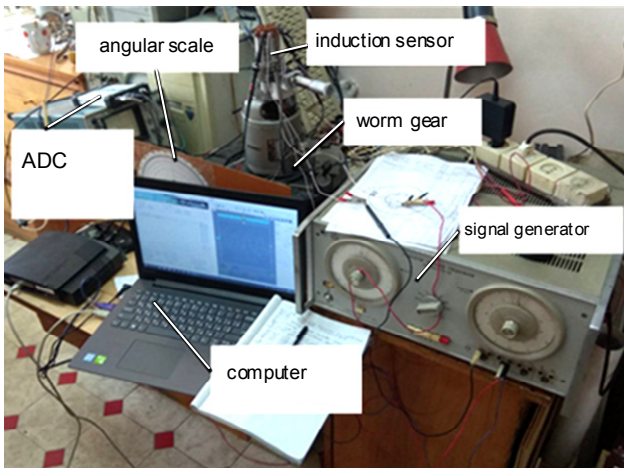

Fig. 9. Experimental equipment for determining angular displacements

The composition of such equipment includes the following components: worm gear (Fig. 10), which is designed to position the exact angles of movement, which consists of a worm wheel (position 1.a in Fig. 10) with 588 teeth and a worm shaft (position 1.b in Fig. 10), connected to an angular scale (Fig. 9), which has 360 divisions. Therefore, the rotation of the worm shaft by 360 divisions of the scale corresponds to the fact that the worm wheel will move by $1.068 \cdot 10^{-2}$ rad. Therefore, moving the worm shaft by one scale division will move the worm wheel by $2.967 \cdot 10^{-5}$ rad.

As an induction sensor (Fig. 9) a rotating transformer VT-5 KF3.031.104 (Fig. 11,a) of accuracy class A, the nominal technical parameters of which correspond to the data of Table 1 was used. Excitation of such a sensor with the required voltage and frequency is carried out using a laboratory two-channel signal generator type G6-26 (Fig. 11,b).

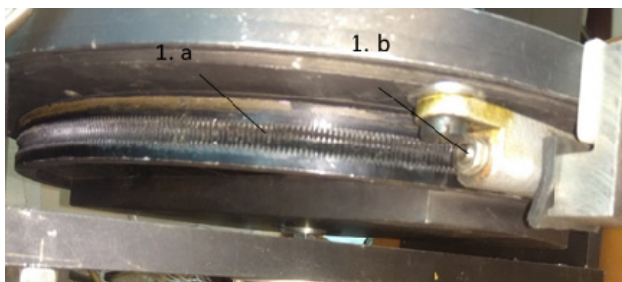

Fig. 10. Worm gear (general view): 1.a – worm wheel; 1.b – worm shaft

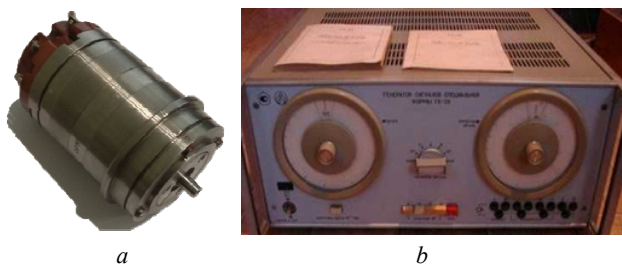

Fig. 11. General view: a – rotating transformer VT-5; b – two-channel signal generator type G6-26

ADC (Fig. 9) and digital oscilloscope INSTRUSTAR ISDS2062B (Fig. 12,a) were used as a converter of input analog signals into a discrete code in the form of an array of values with the subsequent transfer of these arrays via USB interface to a computer (Fig. 9) performing mathematical processing. The MEGATRON M600 optical encoder is also used in the experimental setup for additional control of the accuracy of worm transmission (Fig. 12,b).

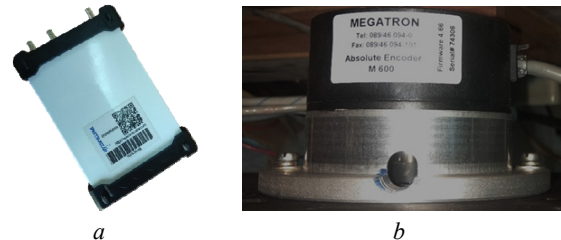

Fig. 12. General view:
a – digital oscilloscope INSTRUSTAR ISDS2062B,
b – optical encoder MEGATRON M600

The description of functioning of experimental installation can be carried out on the basis of use of its structural scheme (Fig. 13).

On the common axis of the installation the worm gear is assembled – 1 (Fig. 13), in which the worm wheel 1.a placed in a horizontal plane with two ends of the output shaft. One end of the output shaft is connected to the rotor of the optical digital encoder 7, and the other end of the output shaft through the adapter is connected to the rotor of the induction sensor of the angle 3. Thus, by rotating the worm shaft 1.b of the worm gear 1, the worm wheel rotates with the output ends of the shaft, and hence the rotation of the rotor of the digital encoder on one side and the rotation of the rotor of the induction sensor on the other side.

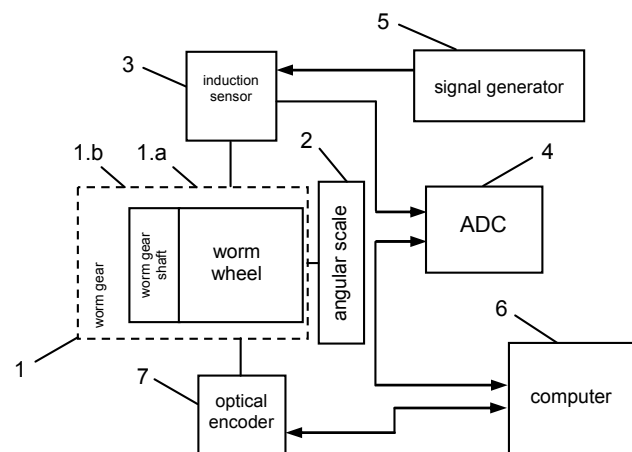

Fig. 13. Block diagram of the experimental installation:
1 – worm gear; 1.a – worm wheel; 1.b – worm gear shaft;
2 – angular scale; 3 – induction sensor; 4 – ADC; 5 – signal generator, 6 – computer, 7 – optical encoder

In turn, the induction sensor 3 receives excitation voltages from the signal generator 5, which are applied to both of its stator windings (excitation windings), and these excitation signals are equal in amplitude and

frequency, but shifted from each other by 90° . To represent the signals in digital form, its windings are connected to ADC 4, the role of which in this installation is performed by a digital oscilloscope, which, in turn, is connected to a computer via a USB interface. Also, a digital optical encoder 7 is connected to the computer for power supply and information exchange via the interface RS-232.

To reflect the results of the study, it was taken into account that in expression (20) as N (number of defined angles) 60,000 values was used, the number of which inevitably affects the root mean square error, but to display this number of experimental values is impossible due to their significant number beyond the scope of this paper. Therefore, the display of the results of determining the angles of rotation of the rotor of the induction sensor relative to its stator will be in the range from 0 to 2π with a step $\pi/4$, which reflects the completeness of the range of determining the values of angles by the proposed method. The results of such a study are given in Table 2, and its graphical representation – in Fig. 14.

Table 2
Results of measuring the angles of rotation of the rotor of the induction sensor in the range from 0 to 2π and the measurement error

Angle of rotation φ , rad	The measurement result by encoder α , rad	The measurement result by the proposed method β , rad	Error, δ rad
0	0	0	0
$\pi/4$	0.7853541	0.785423	$-2.481e-5$
$\pi/2$	1.5707623	1.5707155	$8.078e-5$
$3\pi/4$	2.356187	2.3560015	$1.929e-4$
π	3.1414934	3.1415226	$7.004e-5$
$5\pi/4$	3.9269856	3.9271619	$-1.71e-4$
$3\pi/2$	4.7124053	4.7124368	$-4.781e-5$
$7\pi/4$	5.4977544	5.4979427	$-1.556e-4$
2π	6.2831808	6.2831571	$2.824e-5$

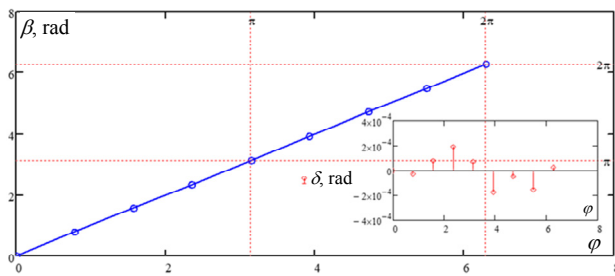

Fig. 14. Dependence of measuring angles β on the angle of rotation of the rotor of the induction sensor φ and the error of their measurements δ

Also, to assess the precision of this method, in the experimental study the values of the angle φ are set in the range from 0 to $2.968 \cdot 10^{-3}$ rad with a step of $1.484 \cdot 10^{-4}$ rad. The results of such studies are given in Table 3. Also Fig. 15 shows the graphical dependencies of the measuring angle β on the angle of rotation of the rotor of the induction sensor φ , and Fig. 16 – dependence of errors δ of the determination of the angle β on the angle of rotation of the rotor of the induction sensor φ .

Table 3
Results of measuring the angles of rotation of the rotor of the induction sensor in the range from 0 to $2.968e-3$ rad

Angle of rotation φ , rad	The measurement result by encoder α , rad	The measurement result by the proposed method β , rad	Error δ , rad
0	0	0	0
$1.484e-4$	$1.5432383e-4$	$3.240248e-4$	$-1.756e-4$
$2.968e-4$	$2.8634171e-4$	$3.9410138e-4$	$-9.73e-5$
$4.452e-4$	$4.4453627e-4$	$6.3563009e-4$	$-1.904e-4$
$5.936e-4$	$5.5750648e-4$	$5.6524419e-4$	$2.835e-5$
$7.42e-4$	$8.1863463e-4$	$1.040776e-3$	$-2.988e-4$
$8.904e-4$	$8.596197e-4$	$6.8755041e-4$	$2.028e-4$
$1.039e-3$	$1.0080408e-3$	$8.3604738e-4$	$2.027e-4$
$1.187e-3$	$1.1244657e-3$	$8.3653092e-4$	$3.507e-4$
$1.336e-3$	$1.2784218e-3$	$1.2367585e-3$	$9.883e-5$
$1.484e-3$	$1.4806882e-3$	$1.6892879e-3$	$-2.053e-4$
$1.632e-3$	$1.5963308e-3$	$1.61913e-3$	$1.325e-5$
$1.781e-3$	$1.7276265e-3$	$1.6229882e-3$	$1.578e-4$
$1.929e-3$	$1.9333049e-3$	$2.0505456e-3$	$-1.214e-4$
$2.078e-3$	$2.0740721e-3$	$2.1002799e-3$	$-2.27e-5$
$2.226e-3$	$2.1709733e-3$	$2.2081033e-3$	$1.787e-5$
$2.374e-3$	$2.3909902e-3$	$2.6908347e-3$	$-3.165e-4$
$2.523e-3$	$2.5283926e-3$	$2.6856021e-3$	$-1.628e-4$
$2.671e-3$	$2.6501764e-3$	$2.7511128e-3$	$-7.994e-5$
$2.82e-3$	$2.7910538e-3$	$2.5065176e-3$	$3.131e-4$
$2.968e-3$	$3.0097617e-3$	$2.9269924e-3$	$4.097e-5$

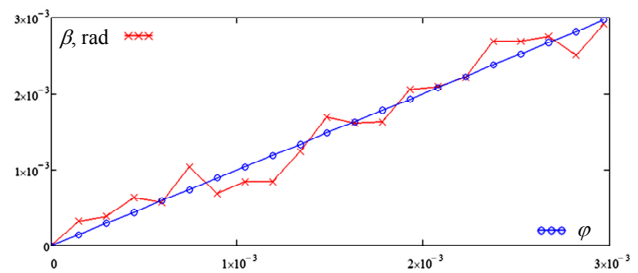

Fig. 15. Dependence of the measuring angle β on the angle of rotation of the rotor of the induction sensor φ

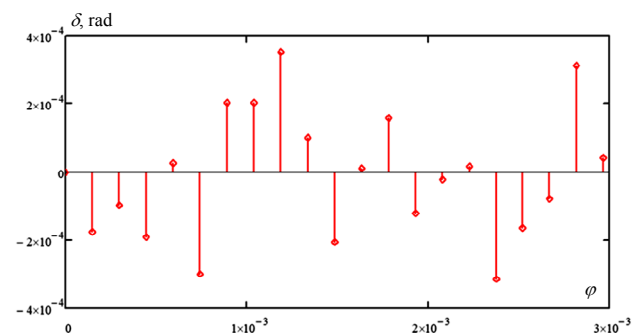

Fig. 16. Dependence of errors δ of the determination of angle β from the angle of rotation of the rotor of the induction sensor φ

The results of the obtained values of errors δ , which are listed in Table 3, with their subsequent substitution in expression (20), allow to estimate the root mean square error of determining the angles of rotation of the rotor of

the induction sensor relative to its stator. The result of this calculation is $1.913e-4$ rad, and thus allows to confirm a sufficiently high precision of the proposed method.

Conclusions.

1. This paper presents special mathematical software for a new method for reducing the error of determining the angular displacements of the rotor of the induction sensor, which is based on determining the angle of phase shift of the signals. This method uses a circular discrete convolution to achieve the most accurate approximation of the obtained signal values to the cosine and sine, respectively. Then the orthogonal components are determined and the phase shift angle in the full range of $0-2\pi$ of angular displacements is determined with the help of a digital detector.

2. The presented results of computer modeling and the results of experimental research are somewhat different, which can be explained by the fact that during the experimental study an analog-to-digital converter of lower bit size than in the mathematical model is used. However, the obtained results of computer simulation taking into account the high level of signal noise and the results of experimental research allow to confirm the high precision of this method and the fact that it can be used in systems where high positioning accuracy is required and the sensor shaft speed is close to zero. .

3. The authors propose software and hardware to solve this problem, and its implementation can be carried out on the basis of the use of commercial analog-to-digital converters and inexpensive microprocessors. However, the parameters of such electronic components will influence on the accuracy and speed of determining the angles of movement of the rotor of the induction sensor by the proposed method, and therefore it involves developing a methodology for choosing hardware and its impact on the accuracy and speed of the angle measurement process which may be the next development of research in this field.

REFERENCES

1. Hicks T., Atherton P. *The Nano Positioning Book: Moving and Measuring to Better Than a Nanometre*. ISTE Publishing Company, 1997. 120 p.

How to cite this article:

Snitkov K.I., Shabatura Y.V. A method of reducing the error in determining the angular displacements when using inductive sensors. *Electrical engineering & electromechanics*, 2020, no. 6, pp. 3-10. doi: 10.20998/2074-272X.2020.6.01.

2. Auger F., Mansouri-Toudert O., Chibah A. Design of advanced resolver-to-digital converters. *Modeling and Simulation of Electric Machines, Converters and Systems. 10th International Conference ELECTRIMACS*. Cergy-Pontoise (France), 6-8 June 2011.

3. Sivappagari C.M.R., Konduru N.R. Review of RDC soft computing techniques for accurate measurement of resolver rotor angle. *Sensors and Transducers*, 2013, vol. 150, no. 3, pp. 1-11.

4. Zavgorodny V.D., Moroz V.I., Petrova O.A. Quantum-mechanical model of induction type angle sensors (Part 4. Analysis of output signal processing methods). *Electrical engineering & electromechanics*, 2003, no. 4, pp. 36-41. (Ukr).

5. Verma A., Chellamuthu A. Design considerations for resolver-to-digital converters in electric vehicles. *Analog Applications Journal*, 2016, vol. Q1, pp. 9-13.

6. Benammar M., Gonzales A.S.P. A Novel PLL Resolver Angle Position Indicator. *IEEE Transactions on Instrumentation and Measurement*, 2016, vol. 65, no. 1, pp. 123-131. doi: 10.1109/TIM.2015.2476280.

7. Wang S., Kang J., Degano M., Buticchi G. A Resolver-to-Digital Conversion Method Based on Third-Order Rational Fraction Polynomial Approximation for PMSM Control. *IEEE Transactions on Industrial Electronics*, 2019, vol. 66, no. 8, pp. 6383-6392, doi: 10.1109/TIE.2018.2884209.

8. Wang Y., Zhu Z., Zuo Z. A Novel Design Method for Resolver-to-Digital Conversion. *IEEE Transactions on Industrial Electronics*, 2014, vol. 62, no. 6, pp. 3724-3731. doi: 10.1109/tie.2014.2375254.

9. Shabatura Y.V., Snitkov C.I., Seredyuk B.O. Mathematical model for determination of angular variables using the angular induction sensor in the phase mode for guiding a typical artillery system. *SDirect24*, 2018, no. 2/(7). Available at: <https://www.sdirect24.org/nato-deep-no-7> (accessed 15 June 2020).

Received 23.09.2020

Accepted 08.11.2020

Published 24.12.2020

K.I. Snitkov¹, adjunct,

Y.V. Shabatura¹, Doctor of Technical Science, Professor,

¹ Hetman Petro Sahaidachnyi National Army Academy,

32, Heroes of Maidan Str., Lviv, 79026, Ukraine,

e-mail: canstantin@gmail.com, shabaturayuriy@gmail.com