

M.I. Baranov

AN ANTHOLOGY OF THE DISTINGUISHED ACHIEVEMENTS IN SCIENCE AND TECHNIQUE. PART 33: ELECTROMAGNETIC COMPATIBILITY AND PROTECTION FROM ACTION OF POWERFUL ELECTROMAGNETIC INTERFERENCE OF RADIOELECTRONIC, ELECTRICAL ENGINEERING AND ELECTRIC POWER EQUIPMENT

Purpose. Implementation of brief analytical review of basic scientific and technical achievements in area of electromagnetic compatibility (EMC) and protection from destabilizing and striking action of powerful electromagnetic interference (PEMI) of natural and artificial origin of radioelectronic, electrical engineering and electric power equipment. Methodology. Scientific methods of collection, analysis and analytical treatment of scientific and technical information in a sphere EMC and such areas of knowledge's as radioelectronics, electrical engineering and electric power engineering. Results. A brief scientific and technical review is resulted modern positions problems EMC and protection of equipment from action on them PEMI. It is shown that PEMI can result in failures in-process and death of examined equipment. Annual harm in the industrially developed countries of the world from the striking affecting of PEMI modern equipment with integral microcircuits and semiconductor devices can make ten of milliards of USD. The basic methods of protection of equipment are resulted from PEMI and protective devices (PD), intended for the increase of effectiveness of modern equipment to the action of external PEMI. Principles of work of the resulted PD and their basic technical descriptions are described. Originality. On the basis of materials of scientific monographs, journal publications, normative documents and internet-reports systematization of basic PD, in-use presently in an area EMC and protection of different equipment from the hazard agency of external PEMI is executed. Practical value. Popularization of scientific and technical knowledge's in an area EMC and protection of modern equipment from a dangerous action on them PEMI. Formulation of important for society scientific and technical problems and tasks, arising up in an area EMC and providing of the reliable functioning of modern equipment in power electromagnetic interference. References 50, figures 25.

Key words: electromagnetic compatibility, equipment, powerful electromagnetic interference, protection of equipment from electromagnetic interference, protective devices, review.

Приведен краткий аналитический обзор основных научно-технических достижений в области электромагнитной совместимости технических средств, методов и устройств защиты радиоэлектронного, электротехнического и электроэнергетического оборудования от внешнего воздействия на него мощных импульсных электромагнитных помех, содержащих высокие напряжения, большие токи и сильные электромагнитные поля. Библи. 50, рис. 25.

Ключевые слова: электромагнитная совместимость, технические средства, мощная электромагнитная помеха, защита технических средств от электромагнитных помех, помехозащитные устройства, обзор.

Introduction. Uninterrupted operation of the modern diversified electronic, electrical and power equipment, to provide linking practical implementation are important for a variety of industrial production and technologies, strategic military-technical objects and everyday citizens of any country in the world electrotechnological processes are directly related to the implementation of strict requirements for its *electromagnetic compatibility* (EMC) and protection from destabilizing the second and the harmful effect of external *powerful electromagnetic interference* (PEMI) of natural and artificially origin [1-3]. It is necessary to remind the reader that is currently under the EMC of equipment refers to the ability to operate the vehicle with a given quality at a given electromagnetic environment (EME) and not cause harmful on the amplitude-time parameters (ATP) of electromagnetic interference with other equipment [3]. We point out that in the field of EMC, the term «*electromagnetic interference*» means one or other electromagnetic process, which impairs or may impair the functioning of the equipment, as well as adversely affect the vital functions of the living organism [3]. As for the equipment concepts, then under it in the EMC field refers equipment, apparatus, product, component parts, the functioning of which is based on the known laws of such on-scientific and technical disciplines like electrical

engineering, radio engineering, electricity and electronics, which in its composition contains various electronic components and circuits that perform the following functions: generation, conversion, transmission, reception, storage and switching magnetic and electrical quantities [3]. It should be noted that in the field of EMC the *interference immunity* of the equipment means the ability of the equipment to maintain a given quality of operation when subjected to external electromagnetic interference with regulated values of ATP, given the relevant regulations [3]. Under electromagnetic resistance (*interference resistance*) of equipment in the solution in the EMC field applications means the ability of the vehicle to provide a predetermined quality function and its operation only until certain ATP levels affecting it PEMI specified in the relevant national (international) standards and published scientific and technical literature [4-14]. Continuously expanding worldwide scope of application in the equipment highly sensitive to the effects of PEMI microprocessor devices for control, registration parameters, information exchange and automation of technological processes objectively lead to increased relevance of EMC problems in modern technology [3].

1. Main sources and types of PEMI. First of all, we note that [5, 15, 17] under PEMI refers to such

© M.I. Baranov

electromagnetic interference, the impact of which on the vehicle is the absence in them interference funds not related to the principles of action and the construction of protected device violation of their normal functioning, temporary glitch device operation (reversible failure) or failure (irreversible failure). Sources occurrence PEMI are divided into two main classes: *the first class* – the sources of natural origin; *the second class* - the sources of artificial origin [5, 15]. The main types of PEMI caused sources of natural origin, are [2, 3, 7, 10, 13-17]: *lightning discharges (lightning)* in the atmosphere, characterized in the microsecond time domain amplitude of current flowing in the dozens (hundreds) kA; a powerful *electromagnetic pulse (EMP)*, formed in the Earth's atmosphere by a high-channel lightning and changing in the microsecond time range; *discharges of static electricity* at its potentials tens (hundreds) of kV, occurring in the initial stage in the nanosecond time range. The main types of PEMI caused by man-made sources, according to [4-9, 11-15, 17-19] include: *switching overvoltage* amplitude of tens kV and *short-circuit currents* amplitude of tens kA, resulting in the millisecond time range in industrial electrical network frequency (50/60) Hz and the contact networks of railway and urban electric transport; discharge *large pulse currents* amplitudes in the tens (hundreds) kA and *high electromagnetic fields* with electric field strength up to (10^2 - 10^4) kV/m and magnetic field strength up to (0.3-30) kA/m generated in the nano- and microsecond timeframes by high (extrahigh) voltage electrical installations intended for scientific and electrotechnological purposes; a powerful EMP generated in the Earth's atmosphere by a nuclear explosion, and changing in the nanosecond time range; a powerful EMP generated in the microwave range of the new type of weapon - electromagnetic weapons, based on non-traditional physical principles of its construction and use.

2. Main methods of devices protection from PEMI. According to [2, 15, 17, 18], the main methods of protection from the action on modern devices PEMI are: first, the *structural method* and, secondly, the *method of circuit*. We emphasize that these methods of protection of devices against PEMI not affect the principles of operation and construction of the devices itself. With their practical use of all the device protection from external electromagnetic disturbances are outside the protected electronic components and electrical circuits of devices. Internal «interference» in the vehicle to be protected in the application of such methods to protect them from the action of external PEMI does not happen. The most common methods of practical implementation of the structural protection of the devices from PEMI the method is the use of *electromagnetic screens* located around the device protected and *grounding devices (GD)* which discharge occurring interfering electrical potentials and currents in the ground [3-5, 7, 15]. The method of circuits for protection of devices from PEMI involves the use in hazardous areas and the approach paths to the following electrical equipment protected [1-7, 15, 18-21]: *protection dischargers; surge arresters; varistors; clamping diodes; combined circuits; protective filters; interference compensation devices; devices for*

electromagnetic isolation of circuits; resistive circuits. Here below the technical features and capabilities of these methods and modern safety devices of the PEMI impact on devices.

3. Electromagnetic screens utilization for the equipment protection against PEMI. Microelectronic and microprocessor technology, communication devices, control systems, information processing and transmission, as well as generating a voltage pulse device (currents) and electromagnetic fields (EMF) special forms and ATP and low-current low-voltage converter equipment are shielded from the effects of external PEMI using metal shells of rectangular, cylindrical, spherical and other geometric shapes [3-7]. Theory of device shielding from external electric and permanent magnetic fields and pulsed EMF variables currently developed for metal shells at a high level [3, 21-23]. The main parameter characterizing the electromagnetic shielding effectiveness of the device when exposed to EMF screen attenuation A_e is defined in decibels according to the following expression [5, 15, 21]:

$$A_e = 20 \lg(E_0 / E_i) = 20 \lg(H_0 / H_i), \quad (1)$$

where E_0 , H_0 are respectively the strengths of electrical and magnetic fields acting from outside on the screen and device protected by it; E_i , H_i are respectively the strengths of electrical and magnetic fields penetrated through wall of the screen into its internal area (screening area against EMF) and acting directly on the protected device.

As a rule, the value of strengths E_0 and H_0 presenting in (1) are set. The strength values E_i and H_i can be determined from the calculated ratios, given, for example, for the quasi-stationary mode of penetration of low- and high-frequency EMF different spatial orientation in the non-magnetic and flat, cylindrical and spherical screens in [3, 21-23]. We recall that in the steady-state approximation theory provides screens at finding solutions to Maxwell equations using a single limit consisting in the fact that the wavelength of entering the EMF shield should be much more basic geometric dimensions of the screen used. From (1) it follows that at $E_0/E_i=H_0/H_i=10^3$ screen attenuation of 60 dB numerically. This attenuation of external PEMI through the use of a metal screen corresponding geometric and electrical parameters is sufficient for reliable operation in the standard mode of virtually any of the protected equipment from the above mentioned contact technology. To enhance the screen effect (increase in (1) the numerical values of the ratios E_0/E_i and H_0/H_i) when electromagnetic and magnetostatic shielding protected the vehicle as additional screening tools in the areas of screens irregularities (for example, covers, hatches, vents, etc.) are applied electrically conductive sealing gaskets, conductive waveguide attachment, honeycomb grille, electrically conductive, thin conductive mesh and other screen elements [4, 15, 24].

Note that to create a screen, the attenuation of the field coming from outside electromagnetic interference, can be used metal building with protected devices including steel reinforcement of its concrete elements, equipotential conductors and grounding system [3]. In practice, you must strive to create around the screen

protected devices with a maximum value with respect to (1) screen attenuation A_e . To this end, all metal engineering communications (e.g. pipes, ventilation ducts, the shell of cable products, etc.) entering a building with protected equipment, fittings, metal box doors and windows of the building part of the building should be repeatedly galvanically (electrically) connected to each other, the metallic screen and grounding circuit [3].

4. Grounding devices utilization for the equipment protection against PEMI. The use of GD is one of the most common methods of equipment protection from the influence of their work interference (the induced) of voltages and currents, caused by exposure to these external PEMI and secure environment equipment service [3, 15, 25]. Therefore, in modern conditions the equipment GD considered by us, especially for electric power facilities, must comply with the requirements in the field of EMC and electrical safety of people [26]. These requirements are intended to perform application tasks and equipment protect their staff from PEMI, mainly arising, in particular, due to switching on power in electric networks of power frequency (50/60) Hz, and the impact of the lightning surge currents [27]. GD usually comprises a grounding conductor is rigidly connected to the grounding part of the device (e.g., with a metal screen housing of the equipment) and grounding made of a recessed metal which is in contact with the ground. Components of GD designed to drain into the land of the induced electromagnetic interference in a metal case, screen equipment charges and potentials, reduce stress touching the metal chassis-screen device and step voltage near the protected device (e.g., control cabinet in the territory of the electric power facilities as a substation) to safe levels [3, 15, 25-27]. Currently, GD for electric power objects (EPO) in many of the world countries is normalized, mainly for the grounding resistance values (from fractions to tens of Ω), building on the GD (from hundreds of V to tens of kV) and touch voltage (tens to hundreds V) [27, 28]. The numerical values of these standardized parameters depend strongly on the structural GD performance, the electrical parameters of the soil in which the memory of the grounding and electrical parameters of the protected object (e.g. power object to such parameters include a valid value short-circuit current, the response time of relay protection, voltage class, etc.) [28-30]. Long-term practice of operation of various electrical and power equipment as a part of industrial energy systems shows that the quality and performance of the character it depends essentially on EME GD and respect for him EMC requirements [3]. As a useful technical information on the GD in the power sector, we note that in [31] was introduced long held practically tested at power in Ukraine method of electromagnetic diagnostics (EMD), the state of their GD. When the EMD GD is running at under voltage electricity equipment control of structural memory execution is carried out, as a rule, by an induction method [26, 31].

According to [3, 15, 27] in solving problems of electrical safety personnel and EMC are three types of grounding used for equipment: the first type – *grounding of lightning protection* intended to divert into

the ground pulse current of lightning is usually characterized for its impulse components for up to 500 μs normalized amplitude up to 200 kA and long lasting components to 1000 ms averaged amplitude of 200 A [8, 13, 14]; the second type – *protective grounding* used to ensure the safety of the operating personnel of equipment by galvanic connection of the metal parts of electrical equipment which in normal operating conditions, have practically zero potential, and in the emergency mode of operation may be under stress, to the contour of the ground; the third type – *working grounding*, designed to create a reference equipotential level in electrical circuits and equipment systems, providing the required conditions for the normal mode of operation. In practice, while ensuring effective protection of EPO from the harmful effect of external PEMI applied the concept of the band to protect their equipment and therefore a holistic approach in the use of memory, providing for the installation in different zones of the protected EPO and equipment simultaneously the three types of grounding [3, 15, 26, 27].

5. ATP of main overvoltages at equipment protection against PEMI. According to [3, 18] and the requirements of GOST R 54149-2010 [32] on the quality of electricity in the air dangerous paths (cable) transmission lines, communication lines and control, «suitable» to the equipment EPO from lightning and switching in electricity may occur lightning impulse with an amplitude U_m up to 10 kV at the entrance to the building with protectable equipment (and with amplitude U_m up to 6 kV in the internal wiring of the building with equipment) and switching to the amplitude of U_m up to 4.5 kV overvoltage (Fig. 1).

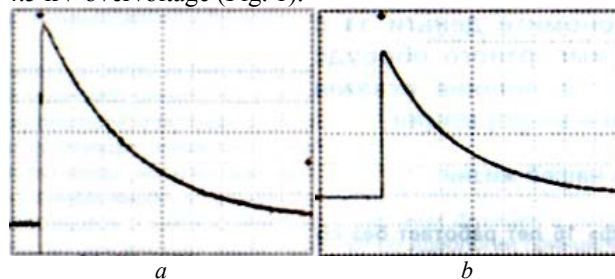

Fig. 1. Lighting (a) and switching (b) overvoltages of aperiodic form at the entrance to the building acting on the equipment (for a – 1/50 μs ; $U_m=10$ kV; the horizontal scale – 25 $\mu\text{s}/\text{cell}$; for b – 250/5000 μs ; $U_m=4.5$ kV; the horizontal scale – 2500 $\mu\text{s}/\text{cell}$) [18]

Network voltage «gaps» and «bursts» are possible. These «gaps» and «bursts» of the voltage in the equipment power supply network can be caused by emergency situations (open neutral when, instead of 220 V may appear voltage up to 380 V) and congestion in the electricity grid caused by connection (especially in winter), large the number of electric heaters. In the latter case, the equipment voltage power network instead of the required 220 V may continuously be in the range (160-180) V [18]. Fig. 2 shows the possible surge of the «gaps» and «bursts» in the power supply voltage.

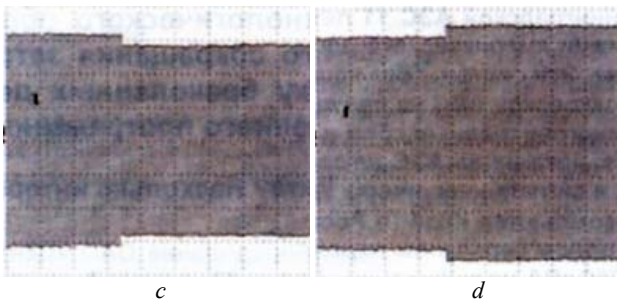

Fig. 2. Overvoltages in the supply network of protected devices caused by the «gap» (c) and the «burst» (d) for 10% of supply network voltage [18]

In addition, the dangerous paths of the above lines, «suitable» to the technical building with protected equipment, because of their exposure to the switching damped sinusoidal currents in EMP said electromagnetic nature may experience high «ringing wave» type surge frequency up to 0.1 MHz U_m amplitude up to 4 kV or at a frequency of 1 MHz at U_m up to 2 kV [18].

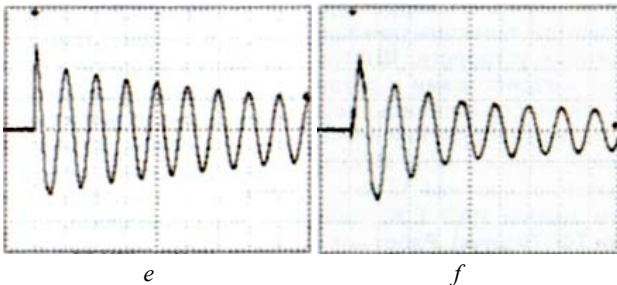

Fig. 3. Overvoltage of «ringing wave» type frequency up to 0.1 MHz with amplitude U_m up to 4 kV (e, the horizontal scale – 10 μ s/cell) and frequency of 1 MHz with amplitude U_m up to 2 kV (f, horizontal scale – 1 μ s/cell) in dangerous paths lines entering the building with protected equipment [18]

When choosing protection devices against interference with the equipment you must not forget about the possible surges in the electrical grid caused by short «bursts» feeding device voltage from 220 to 380 (Fig. 4,g), as well as the transient interference voltages aperiodic time form 5/50 ns with an amplitude U_m up to 2.5 kV (Fig. 4,h), «coming» on dangerous paths before us line to the entrance of the building with protected equipment [18]. Using the above data for the ATP major surge arising in «suitable» to the building with the equipment paths, consider further possible ways of their limitations.

We mention the fact that in 2012 at the Research and Designing Institute «Lightning» of the NTU «KPI» the generator of standard aperiodic switching voltage pulses of positive (negative) polarity temporary form 205/1900 μ s with amplitude of up to 2000 kV was created that meets the current requirements of today interstate [9] and is designed for field testing of full-scale power generation facilities to the electric strength of the outer (inner) insulation [33].

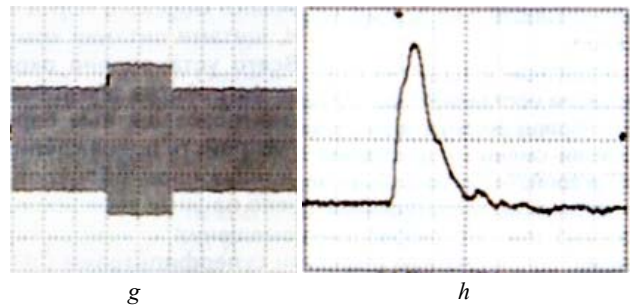

Fig. 4. Overvoltage in the mains protected and due to short-term «burst» are inside equipment building supply mains voltage from 220 to 380 V (g) and overvoltage in a dangerous path «suitable» to the entrance of the building with equipment caused by nanosecond pulse interference temporary form 5/50 ns (h, $U_m=2.5$ kV; the horizontal scale – 50 ns/cell) [18]

6. Some peculiarities of protection of low- and high-current equipment against PEMI.

Disconnection of overvoltages (currents) of short-circuit and switching overvoltages (currents) in the industrial power supply low- and high-current devices or acting on their impulse currents (overvoltages) of lightning by electromechanical switches (EMS) it would probably be the simplest and most reliable protection of the equipment from the action on the they overvoltages from data PEMI. However, the work is especially low-voltage electronic circuits and related electronic and other electrical equipment at the indicated times and external PEMI by EMS operation in hundreds of ms is absolutely impossible. To implement the protection of such equipment their application of only EMS is not enough. In this case, to protect low- and high-current devices circuits by threatening them fast transient electromagnetic processes caused by emergency situations (e.g., short-circuit, switching, lightning strike and other factors), in the «appropriate» to them networks of power supply, cables, and the resulting they need such interference protection devices (IPD) which are able to disable (limit to safe levels) specified overvoltage (currents) for the dozens (hundreds) of nanoseconds. We will try to consider the following basic IPD suitable for the protection of the low- and high-current device circuits of the action of overvoltages caused by external PEMI of different nature.

7. Dischargers application for the equipment protection against PEMI. Most current IPD on the first (rough) restrictions stage affecting the protected devices overvoltaged contain two-electrode gas-filled high-voltage (less air) gaps [3, 15, 18, 34, 35]. Gas-filled surge arresters (Fig. 5) installed near the places of input power buses, potential equalization and grounding in the protected objects from the vehicle. Their task is to ensure the protection of the vehicle from the effects of the possible overvoltage by reducing them to a small level. Voltage their trip due to time-dependent characteristics of the ignition fuses is difficult to determine. They have sealed glass (ceramic) body filled with noble gas (argon or neon) [3, 35]. Metal electrodes in their discharge gap covered with a special thin layer of activator. They are capable of switching current pulses time 8/20 μ s with amplitude of up to 40 kA. In order to ensure the spread of small bit DC, these gaps are in a weak radioactive coating [3, 35].

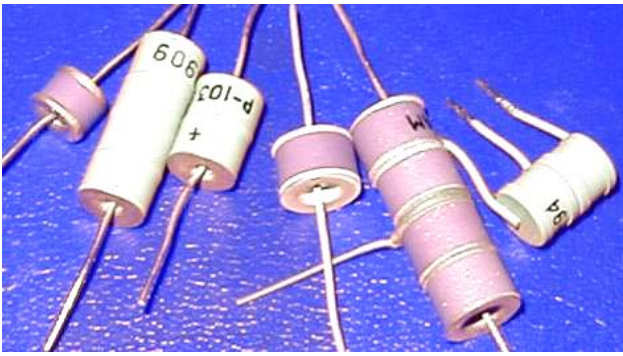

Fig. 5. External view of low-power gas-filled surge arresters (type P-103, and others) that can «skip» pulse currents 8/20 μ s with amplitude of up to 10 kA [35]

After the ignition of gas-filled voltage arrester between their first electrodes decreases to the glow discharge voltage (up to 100 V) and then with increasing switching current – to the electric arc voltage (to about (10-20) V) [3]. This type of arrester is triggered in the microsecond range (response time for their best designs up to microseconds). The AC voltage circuits they arc with accompanying shock itself unable to extinguish. In low-voltage networks DC arc like gas arrester extinguish independently [35].

Fig. 6 is an external view of the gas-filled surge arresters type the GDT, able to dissipate relatively high heat, «introduced by» in PEMI chain. Gas-filled dischargers GDT are used in telecommunications equipment, telephones and radio transmission equipment.



Fig. 6. External view of gas-filled dischargers GDT used in remote control and radioengineering [35]

It should be emphasized that own electric capacity of these gas-filled surge arresters is extremely small. So they cannot make a material misstatement of the useful electric signal. [35] Fig. 7 is an overall view of powerful lightning protection dischargers (RF) that can protect expensive electronic equipment from the direct effects of lightning current discharges [36].

Shown in Fig. 7 lightning protection dischargers are able to «pass» through itself and then sent to the standard grounding aperiodic current pulses 10/350 μ s lightning amplitude to (50-100) kA [36]. The main objective of these fuses when the vehicle protection PEMI is to limit the lightning surge to a residual level prescribed by it (from 1 to 2.5 kV) [35, 36]. Fig. 8 is an external view of foreign lightning protection dischargers with some of the best specifications [35].



Fig. 7. External view of powerful lightning protection dischargers used in the protection of electronic equipment against overvoltage caused by a direct blow to it of lightning (from left to right: P-77-1B and P-59 type) [36]



Fig. 8. The appearance of powerful lightning protection dischargers COMBTEC VV 335 and COMBTEC VS 335 type switching pulse currents 10/350 μ s lightning amplitude of up to 40 kA and limiting lighting overvoltages for electrical equipment to the level of 1 kV [35]

Fig. 9 presents a «line» of LV lighting protection dischargers (LPDL) developed by «EMSOTECH» Company (RF) [18, 37], designed to protect low-voltage bushings (220/380 V) in the building of low-voltage windings of transformers, autonomous energy sources (e.g., diesel-generators) and cable insulation from the effects of lightning and switching surges. These LPDL can reliably switch the lightning current pulses of a standard form of temporary 10/350 μ s with an amplitude I_m 25 to 100 kA [18, 37].



Fig. 9. External view of powerful LV lighting protection dischargers ПГЗН type (from left to right: ПГЗН-3/100-220 for $I_m=100$ kA; ПГЗН-3/50-220 for $I_m=50$ kA; ПГЗН-3/25-220 for $I_m=25$ kA; «EMSOTECH» Company, Kaluga, RF) [18, 37]

On the basis of these dischargers ПГЗН-3/100-220 (see Fig. 9) by specialists of the Russian «EMSOTECH» Company were created panels lightning protection, low-

voltage type ПГЗН (Fig. 10) which in 2010 found their practical implementation of the new system of lightning protection modern radio-complex of the RF to recognize space objects, the external view of which is shown in Fig. 11 [18].

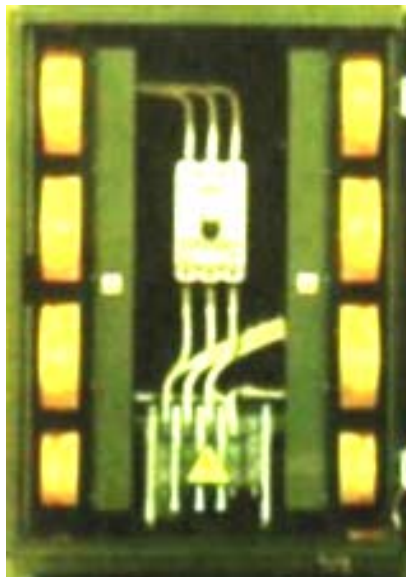

Fig. 10. General view of the panel low-voltage lightning protection redundant type ПГЗН-P-3/100-220 ($I_m=100$ kA; discharger type – ПГЗН-3/100-220; impulse breakdown voltage of each of eight dischargers – 4 kV; RF) [18, 37]



Fig. 11. General view of a unique radio-optical recognition complex of space objects (RF) equipped with a number of lightning protection panels type ПГЗН-P to protect against direct strokes of lightning in its elements [18, 37]

8. The use of overvoltage protective devices for the equipment protection against PEMI. Currently, non-linear overvoltage protective devices (OPD) are one of the most effective means of protection from various devices PEMI [38]. OPD (Fig. 12) is a high-voltage electrical apparatus designed to protect power grids of medium and high grade AC power frequency voltage and therefore we are considering switching from electrical and atmospheric (storm) surge. This unit can be called «*discharger without spark gaps*» [38]. Unlike traditional valve dischargers with spark gaps and carborundum resistors OPD does not contain spark gaps and consist only of the nonlinear resistors column («*pellets*») performed on the basis of zinc oxide and enclosed in a porcelain or polymer casing. The design of the OPD

allows their production in the form of one-column and multi-column devices.



Fig. 12. General view of widely used in power industry one-column OPD with polymer tires, providing reliable protection of their nonlinear resistors weatherproof [38]

The main element of the nonlinear resistors in OPD is a *varistor* performed usually in the form of «*tablets*» of zinc oxide (ZnO) with an outer sheath of glyptal enamel boosting its throughput current value [38]. Varistor material based on said oxide mixed with other metal oxides is a semiconducting structure consisting of a plurality of series-parallel connected *p-n* junctions [38]. This material, as compared with the resistor material in valve arresters has an increased capacity and highly linear current-voltage characteristic (CVC). It is because of this CVC varistors and, accordingly, the OPD can be energized for a long time, which provides a high level of protection of electric power equipment [38].

In normal operating mode, the current through the OPD is capacitive in nature and amounts to a few tenths of mA. If you have PEMI and therefore the impact on the non-linear resistors surge arrester their working material goes into a conducting state with low resistance, thereby limiting further growth overvoltage to a level safe for the protected electrical insulation and other equipment [38]. At the same time through the arrester can «*pass*» pulse currents with amplitudes of tens of kA. With the disappearance of the overvoltage OPD returns to its original non-conducting state. The values of operating voltages for OPD vary widely – from 3 to 750 kV [38-40]. The main places of installation of high-voltage arresters are open (closed) at the power distribution devices and approaches to buildings with equipment. Known in the world of manufacturers of such arresters are [38, 39]: «*Dervasil*» (SICAME Group, France); «*Siemens*» (Germany); «*ABB*» (Switzerland); «*SevZapProm*» (RF). In Ukraine, the forefront of manufacturing technology in the OPD 3-150 kV voltage class for the needs of the electric power company took ES «*Polymer*» (Artemovsk, Donetsk region) [40].

Fig. 13 is an external view of single- and multi-phase surge OPD designed to protect consumers of electricity, powered by electric networks with the frequency (50/60) Hz, surge, switching surge, differential surges and high frequency noise [41]. OPD in this case is established between the phase and earth or neutral conductor and earth. This necessarily requires a

grounding wire for the subsequent «reset» pulse of heat from PEMI in grounding.

In actuality, the importance and the urgent need for greater use of OPD in the industrial power generation, high voltage (low voltage) electrical, remote control and electronics indicates that according to the American company «General Semiconductor» financial losses in the US industry of today only on the harmful effect on its development surge infrastructure (current) from the considered PEMI up to 10 billion USD per year [42].



Fig. 13. A general view of one (left) and three-phase (right) OPD used in electric alternating voltage (current) of power frequency (50/60) Hz during input switching, main switchboards and equipment of apartment billboards residential buildings (manufacturer - «Schneider» Company, Germany) [41]

9. Varistors utilization for the equipment protection against PEMI. As we know, the *varistor* is a semiconductor resistor whose resistance varies nonlinearly by an applied voltage thereto [38, 43]. Earlier in the Electrical and Electronics Engineering used varistors fabricated based on silicon carbide. Currently, commonly are used zinc oxide varistors for different values of power dissipation [3, 38]. The varistor has a symmetrical non-linear CVC. With increased acting voltage its resistance drops dramatically. Therefore, at a voltage pulse action on the varistor electric potential appearing on it may be limited. This physical property is used varistors when used in relation to the external electrical circuits protected equipment (Fig. 14) as a protective device against overvoltage limiting PEMI. Varistors respond to their appearance on the pulse voltage for a nanosecond. Therefore, they have a short response time – (20-50) ns. While gas filled surge dischargers are activated in the microsecond time range ($\geq 1 \mu s$) [3, 18, 44].

Fig. 15 shows the combined interference waveform of current i and voltage u of a powerful varistor type Protec BR 150/320 (manufacturer – company «Iskra-protection»; Slovenia) tested the effects of «the incident» at him a standard impulse current of 10/350 μs of artificial lightning [3, 13].

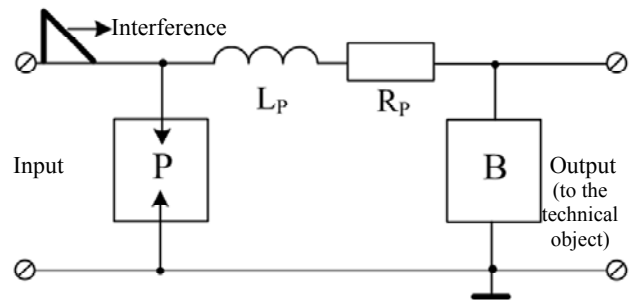

Fig. 14. IPD circuit with two voltage arresters against interference – discharger and varistor (P – high-voltage discharger; B – high-voltage varistor; R_p, L_p – active resistance and inductance of decoupling element in two-line electrical circuit of the IPD) [3]

For ease of processing of experimental data in Fig. 15 u voltage waveform interference on said varistor has been shifted to the right by one cell with respect to the waveform interference current flowing through it i . From the data in Fig. 15 it shows that the interfering current i across the varistor is almost linear decrease in its amplitude of about 21 kA [3]. Voltage u on the test through the varistor 400 μs after the interference amplitude of about 4 kV and accordingly the start of the overvoltage (current) assumes the value of about 1 kV. In was to remain almost unchanged duration of interference pulse current i u simulated lightning voltage across the varistor. However, some distortion in the shape of the voltage pulse interference u in Fig. 15 «made» wire connecting the varistor to our potential and grounded electrical conductors tested protective circuit. In this connection, the wire connection must be carried out in practice is extremely short in length [3]. A common disadvantage of varistors used in power networks with voltages 220/380 device to protect against overvoltage is relatively high residual voltage limitation (1 to 2.5 kV). In this regard, in their application required the second stage overvoltage limitation [3, 38].

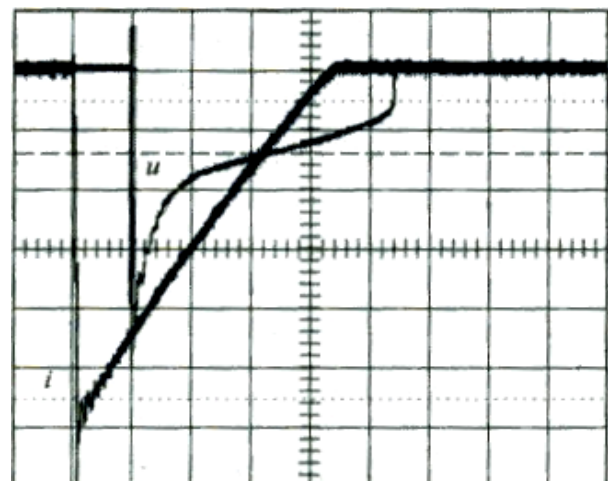

Fig. 15. Combined lightning current waveform interference i of aperiodic temporary form 10/350 μs affecting the varistor voltage and u interference the varistor (the vertical scale for the current – 3.7 kA/cell, the vertical scale for the voltage – 800 V/cell; the scale horizontal for time – 200 μs /cell) [3]

As shown in Fig. 14 protective circuit is necessary to coordinate the arrester varistor parameters P and B . This

coordination can be done through the use of elements of their isolation, as might be used resistors and inductance. The use of coils for decoupling dischargers and varistors is very limited [3]. Typically, such elements as are used wire junction equipment mains. According to the data of [3] between the overvoltage discharger P and powerful high-voltage varistor B the length of the network cables power supplied to the vehicle, should be about 10 m. The length of the wires of the network between the varistor B and protected the device should be at least 5 m [3].

One of the advantages to the gas-filled dischargers varistors is that they are not short-circuited when triggered circuit. Therefore, varistors elements as IPD are used in many power circuits of the device. A relatively large electrical capacitance varistor limits their use in high-frequency electrical circuits (in this case, due to such parasitic capacitance value of the additional attenuation and distortion of the desired signal can occur) [3, 38].

10. Limiting diodes utilization for equipment protection against PEMI. Most sensitive to the effects of surge voltages (currents) induced by EMP natural (artificial) origin, as well as caused by switching and atmospheric (lightning) processes at the «appropriate» to the building of a protectable equipment wires and cables, are the devices connected to them with integrated microcircuits (IMC) and semiconductors. It is known that the minimum energy, causing unrecoverable damage sensitive action PEMI semiconductor devices and IMC ranging from 10^{-2} to 10^{-7} J [7, 42]. In addition to the gas-filled dischargers and metal oxide varistor one of the main security features are also TVS (Transient Voltage Suppressor)-diodes [3, 42]. In the domestic literature they are called «suppressor» or «diodes for transients suppression». TVS-diodes are often confused with Zener diodes [42]. Note that the TVS-diodes have been specially developed for the first time in the United States to protect electronic equipment from various equipment influence on it powerful overvoltages. Silicon Zener diodes intended for voltage control and are not designed to work with large circuits pulsed electric loadings. Abroad TVS-diodes known under the following names: Transil, Insel, Transzorb, etc. We note that the response time for asymmetrical TVS-diode is on the order of 10^{-12} s, and for balanced - about $5 \cdot 10^{-9}$ s [42]. Pulse currents limit for them ranged from a few to hundreds of amperes and voltage limits - from a few to hundreds of volts [3, 42]. Another important characteristic of these diodes is a typical capacitance of $p-n$ junction, is up to 100 pF [42]. This allows the use of TVS-diodes for protection of communication lines with the current frequency to 100 MHz from surge, as well as many radio-frequency circuits, which include sensitive to transient electromagnetic processes of semiconductor devices and IMC. The principle of the TVS-diode which has a pronounced non-linear current-voltage characteristics is explained in Fig. 16. In normal operation of the protected circuit (electrical load) TVS-diode «invisible» and it does not affect its operation. In the event of over-voltage pulse to the TVS-diode, the amplitude of the voltage exceeds its avalanche breakdown, he «opened» and «misses» by itself

on the ground threatening the protected device electric current. At the same time he also carries out and limiting «coming» surge voltage to a safe level [3].

The principal feature of the TVS-diode of the gas-filled dischargers is that their breakdown voltage is below the voltage limit. For arresters same voltage electrical breakdown of the insulating gaps significantly higher discharge sustain voltage. Therefore, when using the TVS-diode protected circuit are not shunted after passing through their $p-n$ junctions powerful impulse noise current.

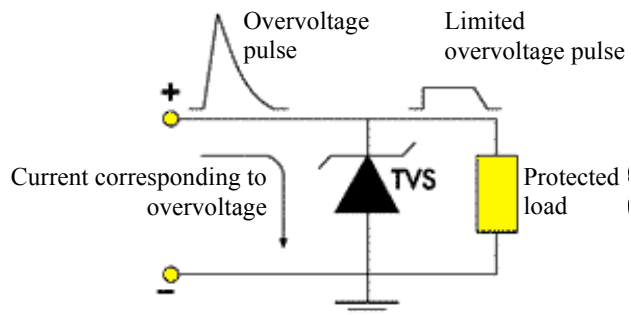

Fig. 16. The simplest electrical circuit explaining the physical principle of TVS-diode operation [42]

11. Utilization of combined IPD for the equipment protection against PEMI. In practice, the protection of many of the devices from the harmful effect they have found application PEMI multistage surge arresters that use both in the same IPD we have described above the gas-filled dischargers, varistors and metal oxide TVS-diodes. In such protective circuits used high performance of some elements and reduces the influence of other elements on the shortcomings of such circuits functioning of the process. Fig. 17 shows the vehicle three-stage protection circuit with overvoltages decoupling elements [3, 7].

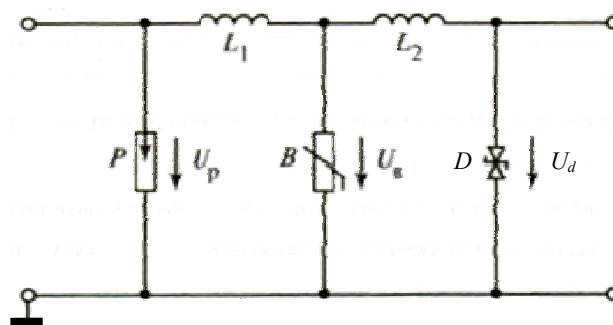

Fig. 17. Schematic diagram of the combined equipment protection with semiconductor devices and IMC from interfering overvoltage and overcurrent (P – gas-filled discharger; B – metal oxide varistor, D – counter included limiting TVS-diodes; L_1, L_2 – decoupling inductances) [3, 7, 15]

When the input to the protection circuit according to Fig. 17 pulse overvoltage or conductive interference TVS-diodes are activated first (*fine protection*) ensuring high speed IPD (up to nanoseconds) [3, 42]. These diodes are capable of passing pulse current interference $8/20 \mu s$ with amplitude of 0.6 kA at a voltage of its avalanche breakdown to 6 V [3, 42]. In this part of the current PEMI diverted to the ground, and at the entrance of the

protected equipment voltage U_{II} is limited in accordance with the CVC used TVS-diode (up to 10 V). Further increasing tension on isolated element L_2 triggers the varistor B , the discharging of the current interference is also on the ground and limiting interference voltage U_B to around 100 V [3]. Then increase the voltage on the decoupling inductances L_1 and L_2 triggers arrester P (coarse protection), in addition to discharging ground current interference. Due to the separation of thermal energy in the spark gap F and the low value of the remaining voltage on it (up to 20 V) facilitates the work of the varistor B . At the same time, a varistor in a certain extent, protect the gap from P electrothermal effect on its working elements PEMI current and possible destruction. The limiting voltage U_p at the discharger P is about 1 kV. Thus, the combined IPD (see Fig. 17) can be realized a significant decrease in overvoltage caused by external PEMI. At the time, this conclusion was confirmed experimentally by the author [45]: three-tier application under consideration device protection scheme PEMI lightning origin enabled through the use of 1,5KE6,8A type TVS-diode ($U_{\text{II}} \approx 6.8$ V), MOV type FNR07K820 ($U_B \approx 135$ V) and the gas-filled spark discharger type LSA140 ($U_p \approx 1.1$ kV) to reliably protect from direct (indirect) impacts RS-485 communication interface lightning line for providing information interaction in a complex EME electronic computing means radio engineering complex, designed and developed in Ukraine.

12. Filters utilization for the equipment protection against PEMI. In the field of EMC and equipment protection from interference, most problems arise from penetration PEMI the protected electrical equipment through the communication circuit, and power management. Therefore, protection of the vehicle power supply networks in the world paid much attention. Fig. 18 is a general view of the German line filter (LF) type FMW2-41-B/1, intended for the protection of industrial power supply circuits in the workplace and at home against pulse PEMI [46]. Schematic diagram of the SF is shown on top of its metal casing monitor. According to Fig. 18 electrical parameters of the LF are: input capacitance – 15 nF; inductances – 0.8 mH; output capacities – 2.2 nF.

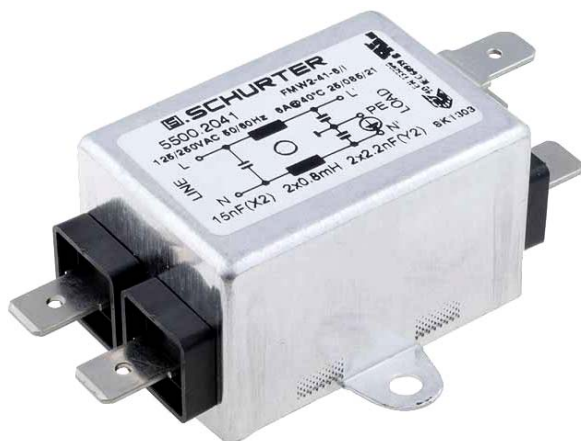

Fig. 18. External view of the line filter for protection against pulse PEMI (current – 6 A; voltage – 250 V; frequency – 50/60 Hz; manufacturer – «Schurter» Company, Germany) [46]

Fig. 19 is a external view of another modification of the German LF used in suppressing PEMI coming by power network wires [3].



Fig. 19. External view of the line filter for the PEMI suppression B84115-E-B30 type (current – 6 A; voltage – 250 V; frequency – 50/60 Hz; manufacturer – «Epcos» Company, Germany) [46]

Typically, LF are a low pass filters (LPF) installed in the power supply circuits of most electronic devices. Fig. 20 is an external view of the inner «filling» EMI-filter used for the protection of automation equipment from the effects of high-frequency PEMI [47].



Fig. 20. External view of the EMI-filter (with open plastic cover of the insulating housing LPF) for protection against impulse interference of automation and control devices (current – 10 A, voltage – 260V, frequency – 50/60 Hz) [47]

Fig. 21 shows a circuit diagram of a interference protection EMI-filter used for suppressing PEMI in automation and control circuits [47].

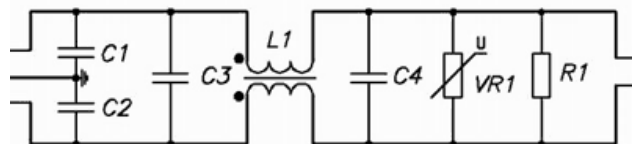

Fig. 21. A circuit diagram of the EMI-filter to for the protection against pulse interference of automation and control circuits

13. Correctors, compensators and relays-voltage circuit breakers utilization for the equipment protection against PEMI. In cases where the mains voltage supply of computer equipment and information (CEI) is reduced to a level of 200 V or less, or increased to a level of 240 V or more, which leads to malfunction

CEI, in order to protect the equipment from external PEMI commonly used voltage correctors (VC). Fig. 22 shows the external views of IPD KH type developed by «EMSOTECH» Company (Kaluga, RF) [18].

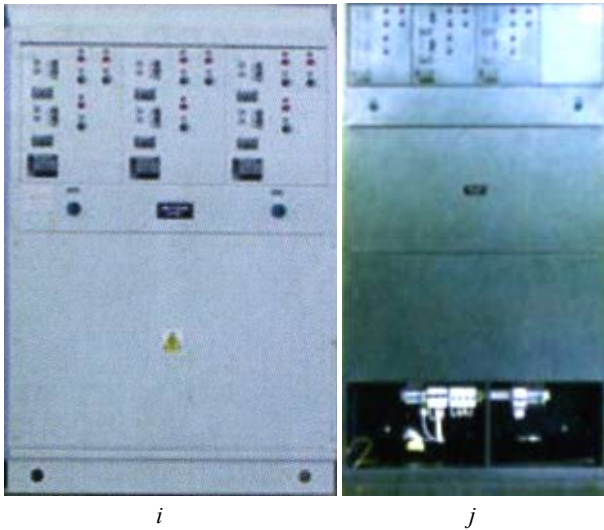

Fig. 22. External views of voltage correctors type KH-T-63-Б (*i*, power – 63 kW; load current – 95 A) and type KH-T-40-C (*j*, power – 40 kW; load current – 60 A) [18]

To protect the supply of higher harmonics and unloading neutral in three-phase networks CEI power compensators applied voltage distortion (CVD). Fig. 23,*k* is a external view of one type of such compensators type КИИ-25-Д (power – 25 kW, the load current – 40 A) [18]. To compensate for the «failures» of the voltage in the power network using triggered after 200 ms compensators of «failures» voltage (CFV) in CEI supply network caused by the influence of her external PEMI [18]. Fig. 23,*l* is an external view of one type of such compensators type КИИ-Т-40-Б (power – 40 kW, the load current – 60 A) [18].

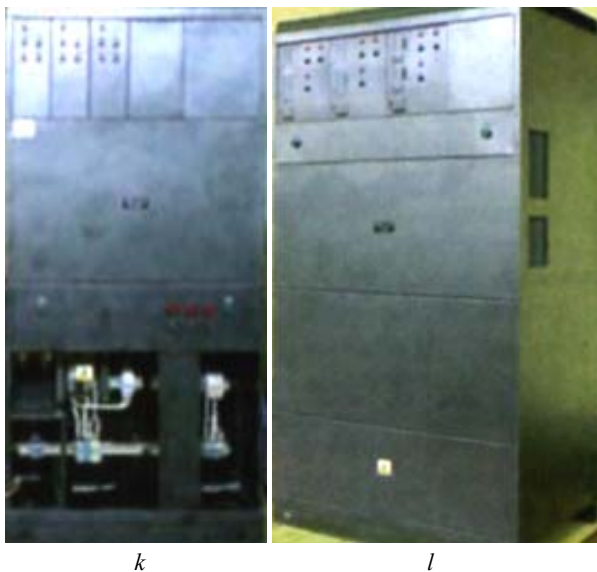

Fig. 23. General views of the power compensator applied voltage distortion type КИИ-25-Д (*k*, power – 25 kW; load current – 40 A) and compensator of «failures» voltage type КИИ-Т-40-Б (*l*, power – 40 kW; load current – 60 A) [18]

Specified in this section IPD (VC, CVD and CFV) effectively protect modern CEI, avionics and electrotechnological equipment, which are critical to a change in power supply voltage to the (20-40) % of the nominal level.

Fig. 24 is a general view of the voltage relay VOLT CONTROL RN-104 type (40 A) produced in Ukraine and intended for disconnection from the network of household power supply (industrial) electronics up to 9 kW to the desired delay in unacceptable voltage fluctuations in its electricity network with automatic insertion after restoring network settings [48].



Fig. 24. External view of the domestic voltage relay type VOLT CONTROL PH-104 (current – up to 40 A; voltage – (160-280) V; delay time – (5-900) s; Ukraine) [48]

14. Electromagnetic isolation of external circuit utilization for the equipment protection against PEMI.

One of effective methods of reducing the influence of external PEMI on the functioning of the equipment inside the building is the external electromagnetic isolation of electrical circuits, «suitable» to the protected building with device or «exhaust» of it [3, 15, 19]. The main methods of electromagnetic isolation of external electrical circuits of considered equipment concerns [3, 15, 19]: application of decoupling inductances are often implemented at the expense of the electrical parameters of «suitable» to the device protected power supply wires; the use of an isolation transformer, installed in the gaps of electrical circuits and grounding circuits; installation in the gap the pair of phase and neutral conductors of the longitudinal choke; use bifilar choke with ferrite rings; application in the chain breaks optoelectronic circuits (e.g., optocouplers, optocoupler diode, transistor optocouplers, optical fiber communication lines, etc.).

15. Resistive circuits utilization for the equipment protection against PEMI. Currently, in the protection of powerful high-voltage capacitor bank energy content in hundreds kJ of fault currents and micro-millisecond duration and amplitude of up to hundreds of kA, capable

of causing destruction explosion-punched high-current electrical discharge capacitors with metal and insulating housings have been used new resistive circuits [49, 50]. Fig. 25 is a general view of a fragment of a powerful high-voltage capacitive energy storage (CES) single-module performance developed by the Research and Designing Institute «Lightning» of the NTU «KPI» and intended to form in laboratory conditions on a low-resistance and low-inductance electrical load major components of pulse current artificial lightning with standardized ATP [49] and which was used to protect the resistive circuit capacitors from its fault currents on the basis of the type of resistors TBO-60-24 Ω .



Fig. 25. General view of a fragment of a powerful high-voltage CES single module performance at a rated voltage of ± 50 kV and rated stores electric energy 420 kJ with its parallel-connected capacitors type ИК-50-3 in the amount of 112 pieces. and rigidly mounted on their findings of high-volume constant high voltage protective graphite-ceramic resistors TBO type-60-24 Ω [49]

The above protection scheme based on the use of the composition of high voltage graphite-ceramic fixed resistors type TBO-60 with value of resistance from 24 to 100 Ω installed directly on the high-voltage output of individual capacitors. In [20, 21] were brought engineering and technical advice on the construction of such protection schemes and approximate ratio calculated by the choice of the protective resistors depending on the developer used a high-voltage pulse technique of constructing principle (single or multi-module version) powerful electrical capacitor banks.

Conclusion. The solution of the global problem of EMC and protection against the harmful effect of PEMI of natural and artificial nature of radioelectronic, electrical and power equipment requires for the successful achievement of the above objectives more active and widespread use on general industrial and domestic levels of effective IPD in various designs.

REFERENCES

1. Khabiger E. *Elektromagnitnaia sovместimost'. Osnovy ee obespecheniia v tekhnike* [Electromagnetic compatibility.

- Fundamentals of its maintenance technique]. Moscow, Energoatomizdat Publ., 1995. 304 p. (Rus).
2. Dyakov A.F., Maksimov B.K., Borisov R.K. *Elektromagnitnaya sovместimost' v elektroenergetike i elektrotekhnike* [Electromagnetic compatibility in power engineering and electrical engineering]. Moscow, Energoatomizdat Publ., 2003. 768 p. (Rus).
3. Dyakov A.F., Kuzhekin I.P., Maksimov B.K., Temnikov A.G. *Elektromagnitnaya sovместimost' i molniezashchita v elektroenergetike* [Electromagnetic compatibility and lightning protection in the power]. Moscow, MEI Publishing House, 2009. 455 p. (Rus).
4. Ricketts L.U., Bridges J.E., Mayletta J. *Elektromagnitnij impul's i metody zashchity* [Electromagnetic pulse and methods of protection]. Moscow, Atomizdat Publ., 1979. 328 p. (Rus).
5. Kravchenko V.I., Bolotov E.A., Letunova N.I. *Radioelektronnye sredstva i moshchnye elektromagnitnye pomехi* [Radioelectronic means and powerful electromagnetic hindrances]. Moscow, Radio and Communications Publ., 1987. 256 p. (Rus).
6. Myrova L.O., Chepizhenko A.Z. *Obespechenie stojkosti apparatury svyazi k ioniziruyushchim i elektromagnitnym izlucheniyam* [Ensuring stability of communications equipment to the ionizing and electromagnetic of radiations]. Moscow, Radio and Communications Publ., 1988. 296 p. (Rus).
7. Kravchenko V.I. *Hrozozashchita radioelektronnykh sredstv* [Lightning protection of radioelectronic facilities]. Moscow, Radio and Communications Publ., 1991. 264 p. (Rus).
8. Baranov M.I. *Izbrannye voprosy elektrofiziki. Tom 2, Kn. 2: Teoriia elektrofizicheskikh effektov i zadach* [Selected topics of Electrophysics. Vol.2, Book 2. A theory of electrophysical effects and tasks]. Kharkiv, NTU «KhPI» Publ., 2010. 407 p. (Rus).
9. *GOST 1516.2-97. Elektrooborudovanie i elektroustanovki peremennogo toka na napriazhenie 3 kV i vyshe. Obshchie metody ispytaniy elektricheskoi prochnosti izoliatsii* [GOST 1516.2-97. Electrical equipment and electrical options of alternating current voltage 3 kV and above. Common test methods for dielectric strength]. Minsk, Publishing house of standards, 1998. 31 p. (Rus).
10. *GOST 30585-98. Stoikost' k vozdeistviyu grozovykh razriadov. Tekhnicheskie trebovaniia i metody ispytaniy* [GOST 30585-98. Resistance to lightning. Technical requirements and test methods]. Kiev, State Standard of Ukraine Publ., 1998. 27 p. (Rus).
11. *GOST R 50746-2000. Sovместimost' tekhnicheskikh sredstv elektromagnitnaia. Tekhnicheskie sredstva dlia atomnykh stantsii. Trebovaniia i metody ispytaniy* [GOST R 50746-2000. Compatibility of technical equipment. Technical equipment for nuclear power plants. Requirements and test methods]. Moscow, Publishing House of Standards, 2001. 42 p. (Rus).
12. IEC 61000-4-32. Part 4-32. Testing and measurement techniques-High-altitude electromagnetic pulse (HEMP) simulator compendium. Geneva, IEC Publ., 2002. 108 p.
13. IEC 62305-1: 2010 «Protection against lightning. Part 1: General principles». Geneva, IEC Publ., 2010. 56 p.
14. *GOST R MEK 62305-1-2010. Menedzhment riska. Zashchita ot molnii. Chast' 1: Obshhie principy* [GOST R IEC 62305-1-2010. Risk management. Protection from lightning. Part 1: General principles]. Moscow, Standartinform Publ., 2011, 46 p. (Rus).
15. Brzhezitskiy V.A., Isakova A.V., Rudakov V.V. *Tekhnika i elektrofizyka vysokikh napruh* [Technics and Electrophysics of High Voltages]. Kharkov, Tornado Publ., 2005. 930 p. (Ukr).

16. Kozlov D.A., Kuzhekin I.P., Hribar J. Testing objects for resistance to lightning currents. *Technologies of electromagnetic compatibility*, 2004, no.2(9), pp. 35-39. (Rus).
17. DSTU 2793-94. *Sumisnist tekhnichnykh zasobiv elektromahnitna. Stiikist do potuzhnykh elektromahnitnykh zavod. Zahalni polozhennia* [DSTU 2793-94. Electromagnetic compatibility of hardware. Stability to the powerful electromagnetic hindrances. General principles]. Kiev, State Standard of Ukraine Publ., 1994. 24 p. (Ukr).
18. Suhorukov S.A. *Pomehozashhitnye ustrojstva ZAO «EMSOTEH»* [Hindrances protective devices of CCA «EMSOTEH»]. Kaluga, 2014. 72 p. (Rus).
19. Kravchenko V.I. *Weapon on non-traditional physical principles: Electromagnetic weapon*. Kharkov, NTMT Publ., 2009. 266 p. (Rus).
20. Baranov M.I. Key indicators thermo protection in high-voltage capacitors charge-discharge circuit powerful capacitive energy storage of emergency overcurrent. *Bulletin of NTU «KhPI»*, 2014, no.50(1092), pp.20-27. (Rus).
21. Baranov M.I., Rudakov S.V. Development of new charts of capacitance-resistance defense of high-voltage capacitors of powerful capacity stores of energy from emergency currents. *Electrical engineering & electromechanics*, 2015, no.6, pp. 47-52. (Rus). doi: 10.20998/2074-272x.2015.6.08.
22. Shapiro D.N. *Osnovy teorii elektromahnitnogo ekranirovaniya* [Basic theory of electromagnetic screening]. Leningrad, Energy Publ., 1975. 112 p. (Rus).
23. Apollonsky S.M. *Raschet elektromagnitnykh ekraniruyushchih obolochek* [Calculation of electromagnetic shielding of shells]. Leningrad, Energoizdat Publ., 1982. 144 p. (Rus).
24. Vance E.F. *Vliyanie elektromagnitnykh polej na ekranirovannye kabeli* [The impact of electromagnetic fields on the shielded cables]. Moscow, Radio and Communications Publ., 1982. 120 p. (Rus).
25. Ryabkova E.Y. *Zazemleniya v ustanovkah vysokogo napryazheniya* [Grounding installations high voltage]. Moscow, Energy Publ., 1978. 224 p. (Rus).
26. SOU 31.2-21677681-19:2009. *Viprobuvannya ta kontrol' prystroyiv zazemleniya elektroustanovok. Tipova instruktsiya*. [SOU 31.2-21677681-19:2009. Test and control devices, electrical grounding. Standard instruction]. Kyiv, Minenergovugillya Ukrainy Publ., 2010. 54 p. (Ukr).
27. *Pravila ulashtuvannya elektroustanovok. Rozdil 1. Zagal'ni pravila. Glava 1.7. Zazemlennya i zakhisni zakhodi vid urazhennya elektrichnim strumom* [Rules of the device electroinstallations. Chapter 1. General rules. Grounding and protective measures against electric shock]. Kyiv, Minenergovugillya Ukrainy Publ., 2011. 72 p. (Ukr).
28. Koliushko G.M., Koliushko D.G., Rudenko S.S. On the problem of increasing computation accuracy for rated parameters of active electrical installation ground grids. *Electrical engineering & electromechanics*, 2014, no.4, pp. 65-70. (Rus). doi: 10.20998/2074-272x.2014.4.13.
29. Kostruba S.I. *Izmerenie elektricheskikh parametrov zemli i zazemlyayushchih ustrojstv* [Measurement of electrical parameters of the earth and grounding device]. Moscow, Energoatomizdat Publ., 1983. 168 p. (Rus).
30. Burgsdorf V.V., Jacobs A.I. *Zazemlyayushchie ustrojstva elektroustanovok* [Earthing devices of electric options]. Moscow, Energoatomizdat Publ., 1987. 400 p. (Rus).
31. Borisov R.K., Koliushko G.M., Grimud G.I. Technique to study the ground grids of electric power facilities. *Energy and Electrification*, 2000, no.4, pp. 29-32. (Rus).
32. GOST R 54149-2010. *Normy kachestva elektricheskoi energii v sistemakh elektroshchitnogo obshchego naznacheniia* [GOST R 54149-2010. Norms of quality of electric energy in power systems for general purposes]. Moscow, Standartinform Publ., 2010. 52 p. (Rus).
33. Baranov M.I., Koliushko G.M., Kravchenko V.I. A switching aperiodic superhigh-voltage pulse generator for testing the electric strength of insulation of technical objects. *Instruments and Experimental Technique*, 2013, vol.56, no.6, pp. 653-658. doi: 10.1134/s0020441213050126.
34. IEC 62305-4: 2010 «Protection against lightning.– Part 4: Electrical and electronic systems within structures». Geneva, IEC Publ., 2010. 59 p.
35. Available at: <http://www.schrack-technik.ru/shop/grozozashchitnye-razrjadniki-razrjadniki-dlja-zashchity-ot-perenapryazhenija-i-zazemlenie.html> (accessed 21 May 2015). (Rus).
36. Available at: <http://www.plasmalabs.ru/files/products/sverhmoshchnie.pdf> (accessed 10 October 2015). (Rus).
37. Available at: <http://newet.ru/catalog/pomekhozashchitnoe-oborudovanie-ems-otekh> (accessed 21 February 2014). (Rus).
38. Available at: <http://electricalschool.info/main/elsnabg/220-primeneniye-ogranichitelej.html> (accessed 28 September 2014). (Rus).
39. Dem'yanenko K.B., Titkov V.V. Comparison of the main technical characteristics of OPN in porcelain and polymer insulation of LLC «SEVZAPPROM». *ELEKTRO. Electrical engineering, power industry, electrical industry*, 2007, no.2, pp. 31-33. (Rus).
40. Shumilov Yu.N., Shumilov M.Yu., Taran V.N., Ganpanturova S.Iu., Kovtun A.N., Tel'manova E.N., Nebogataia V.V., Zaderikhin A.A., Lenev D.N. Non-linear terminators of overvoltage 3-150 kV in polymer corps. *Energetic and electrification*, 2010, no.9, pp. 26-30. (Rus).
41. Available at: <http://electric-talk.ru/ogranichiteli-perenapryazhenij-zashchita-ot-molnii> (accessed 23 July 2015). (Rus).
42. Available at: http://www.compitech.ru/html/cgi/arhiv/01_01/stat-32.htm (accessed 10 April 2015). (Rus).
43. *Bol'shoj illjustrirovannyj slovar' inostrannykh slov* [Large illustrated dictionary of foreign words]. Moscow, Russkie slovari Publ., 2004. 957 p. (Rus).
44. Komel'kov V.S. *Tehnika bol'shih impul'snykh tokov i magnitnykh polej*. [Technique large pulsed currents and magnetic fields]. Moscow, Atomizdat Publ., 1970. 472 p. (Rus).
45. Baranov M.I. *Izbrannye voprosy elektrofiziki. Tom 3: Teorija i praktika elektrofizicheskikh zadach* [Selected topics of Electrophysics. Vol. 3: Theory and practice of electrophysics tasks]. Kharkiv, Tochka Publ., 2014. 400 p. (Rus).
46. Available at: <http://www.musidora.ru/dimFiltrs.htm> (accessed 21 May 2015). (Rus).
47. Available at: <http://www.symmetron.ru/suppliers/infineon/files/pdf/infineon/INF13.pdf> (accessed 10 April 2014). (Rus).
48. Available at: <http://bt.rozetka.com.ua/3502659/c3502659/?gclid=CPeh-OidlckCFebhcgoddGgA1A> (accessed 12 July 2016). (Rus).

49. Baranov M.I., Koliushko G.M., Kravchenko V.I., Nedzel'skii O.S., Dnyshchenko V.N. A Current Generator of the Artificial Lightning for Full-Scale Tests of Engineering Objects. *Pribory i tehnika eksperimenta – Instruments and Experimental Technique*, 2008, no.3, pp. 401-405. doi: **10.1134/s0020441208030123**.

50. Baranov M.I., Koliushko G.M., Kravchenko V.I., Rudakov S.V. A generator of aperiodic current pulses of artificial lightning with a rationed temporal form of 10 μ s/350 μ s with an amplitude of $\pm(100-200)$ kA. *Instruments and Experimental Technique*, 2015, vol.58, no.6, pp. 745-750. doi: **10.1134/s0020441215060032**.

M.I. Baranov, Doctor of Technical Science, Chief Researcher, Scientific-&-Research Planning-&-Design Institute «Molniya» National Technical University «Kharkiv Polytechnic Institute», 47, Shevchenko Str., Kharkiv, 61013, Ukraine, phone +38 057 7076841, e-mail: eft@kpi.kharkov.ua

Received 25.11.2015

How to cite this article:

Baranov M.I. An anthology of the distinguished achievements in science and technique. Part 33: Electromagnetic compatibility and protection from action of powerful electromagnetic interference of radioelectronic, electrical engineering and electric power equipment. *Electrical engineering & electromechanics*, 2016, no.4, pp. 3-15. doi: 10.20998/2074-272X.2016.4.01.